

Hitachi Inverter Hoist Catalog

Hitachi Inverter Rope Hoist

Super V series (Type 4)

One- to Ten-Ton Inverter-Equipped Hoists (Pushbutton Operation)

V8 series (Type 4)

Fifteen- to Thirty-Ton Inverter-Equipped Hoists (Pushbutton Operation)

Inverter-based control

- **Pushbutton with 2 depressed points for changing speed**

The first and second depressed points correspond to the low and high speed settings, respectively.

The low and high speed settings are independent of each other and can be set to any desired speed.

- **Minor vibration of the suspended load**

The starting and stopping impact reduction function reduces load vibrations during hoisting as well as impact on the building and crane girder.

- **Smooth traveling for reduced vibration of the load**

The smooth acceleration and deceleration minimizes the pendular motion of the suspended load during traveling.

- **Reduced impacts on mechanical parts**

Because the brake is applied when the motor rotation speed is low, the abrasion of the lining is reduced and so are impact on mechanical parts such as the wire ropes, sieves, couplings and gears, which means that the service lives of these parts can be prolonged.

- **Load sway suppression function standard**

Inverter-based control reduces the pendular motion of the suspended load. However, when the load is transported, inertia causes the load to sway when the hoist operation stops.

The swaying of the suspended load can be controlled and minimized by a follow-up notch operation performed by the operator. However, this maneuver is difficult for an inexperienced operator.

The load sway suppression function standard automatically performs an operation equivalent to a follow-up notch operation, thereby minimizing the pendular motion of the load. This function eliminates the need for the operator to perform a follow-up notch operation and allows even inexperienced operators to safely and effectively operate the hoist for swift transport of the load to the intended location.

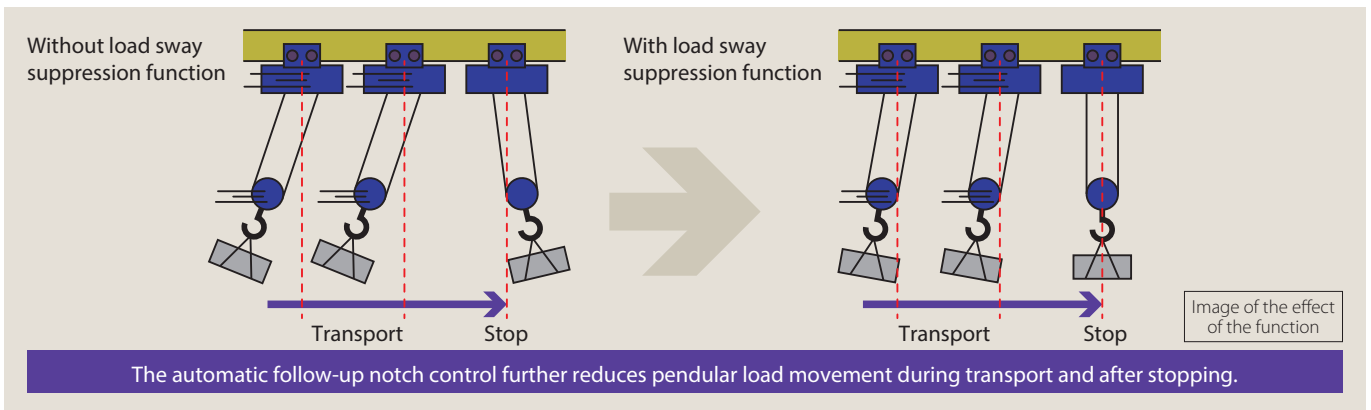

- Notes:
1. This function is disabled at the factory. Refer to the Operating Manual to enable the function.
 2. When the function is enabled, the load must be stationary at the time the transport operation begins.
Note that the load sway suppression function may not be as effective as intended if transport begins with the load already in pendular motion.
 3. When the function is enabled, the traveling speed may increase during the deceleration/stopping operation after the hoist operation is turned off. Make sure the path in which the load is moving is free of people, equipment, and parts before operating the hoist.
 4. If you wish to use the load sway suppression function for the transport of the load in the traveling (saddle) direction, please use the Hitachi inverter unit for saddles (N-1C4/N-5C4 manufactured in or after October 2017).
 5. Set the pushbutton to the first depressed position (low speed) to disable this function and activate the normal starting and stopping impact suppression function.
 6. Disable this function when performing co-hoisting operations.

Configuring the system before using the load sway suppression function

Load sway suppression axis	Configuring the system for load sway suppression		
	Hoist	Connection cable	Saddle control panel
Traversal only		Not required	Not required
Traversal + travel		Signal cable <small>* Items to be prepared by the customer Recommended signal cable Manufacture: Dyden Corporation Model: ROBOTOP DF-SB Number of paired wires: 3 (6 cores) Core wire size: AWG20 (0.5 mm²)</small>	N-1C₄ or N-5C₄ N-10S₄, N-10C₄ N-30S₄, N-30C₄

Note: Use separate cables for the signal line and high-voltage power supply. Do not place the signal cable and high-voltage power cable within the same cable duct or cleat them together. Failure to observe this precaution may result in malfunctions or erratic operations. Keep the length of signal cables to within 40 m.

- **Block diagram of system in which the load sway suppression function is used for traversal and travel**

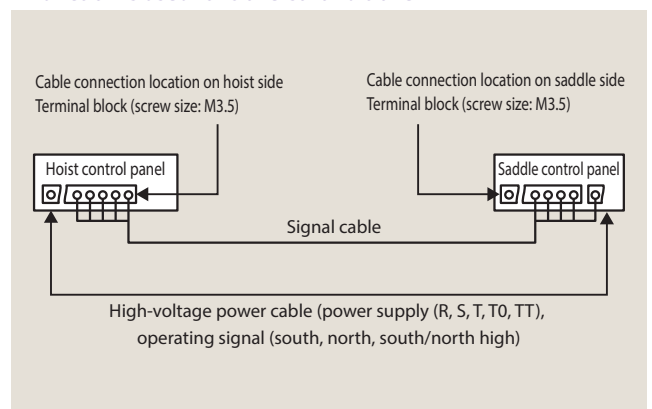

■ Acclaimed functions inherited from previous models.

● Overloading prevention function

When hoisting is attempted of a load that is heavier than the capacity, the hoisting will be stopped automatically.

Note: The overload detection threshold may vary between 100 and 150% of the capacity depending on the operation frequency, source voltage and motor temperature.

● Light-load high-speed operation function

When the hoist is operated with a light load (0% to 30% load), high-speed operation at 150% of the rated speed will automatically be selected.

Notes: 1. The maximum load determined to be a light load may vary between 30% and 40% of capacity, depending on the frequency of use, source voltage, and motor temperature.

2. Certain special high hoist lift hoists cannot be fitted with the light-load high-speed operation function. Please contact us for more information.

3. The light-load high-speed operation function cannot be used in co-hoisting operations. Please contact us for more information.

● Electronic limit switch function

This function detects the hook position to allow hoisting and lowering to be stopped automatically at the set position and to reduce impact.

(The user can easily set the upper and lower limits according to his needs. The upper and lower limits are not factory-set before shipment.)

■ Improved ease of maintenance

● Saving operational information to a USB flash drive

Operational data such as the number of times started, cumulative hours of operation, data on malfunctions, and various settings can be saved to a USB flash drive.

The data saved to the USB flash drive can be viewed on a PC to monitor and manage operating conditions.

Notes: 1. Operational data is output as text data.

2. No USB flash drive is supplied.

● Load-specific operational information display function

In addition to displaying cumulative hours of operation and number of times started for each load, this function also calculates and shows the maximum rate of loading (K) recorded up to the current time power was turned on. This information is useful in planning maintenance.

Note: The load is measured and displayed based on the six categories. The displayed result may deviate from the actual load depending on the frequency of use, source voltage, and motor temperature.

Six categories (1) No load: 0% to 10%, (2) Light load: 11% to 25%, (3) Medium load: 26% to 50%, (4) Heavy load: 51% to 75%, (5) Extra-heavy load: 76% to 100%, (6) Overload: 101% or more

● Wire rope inspection assist function

In addition to displaying the total number of bending times for each 1 m segment of the wire rope and the number of bending times for each load, this function also calculates and displays the top five points (position categories) in terms of the total number of bending times.

This information can be used to inspect the locations of the wire cables that have sustained frequent bending and is useful in cable maintenance and management.

Note: The load is measured and displayed based on the six categories. The displayed result may deviate from the actual load depending on the frequency of use, source voltage, and motor temperature.

Six categories (1) No load: 0% to 10%, (2) Light load: 11% to 25%, (3) Medium load: 26% to 50%, (4) Heavy load: 51% to 75%, (5) Extra-heavy load: 76% to 100%, (6) Overload: 101% or more

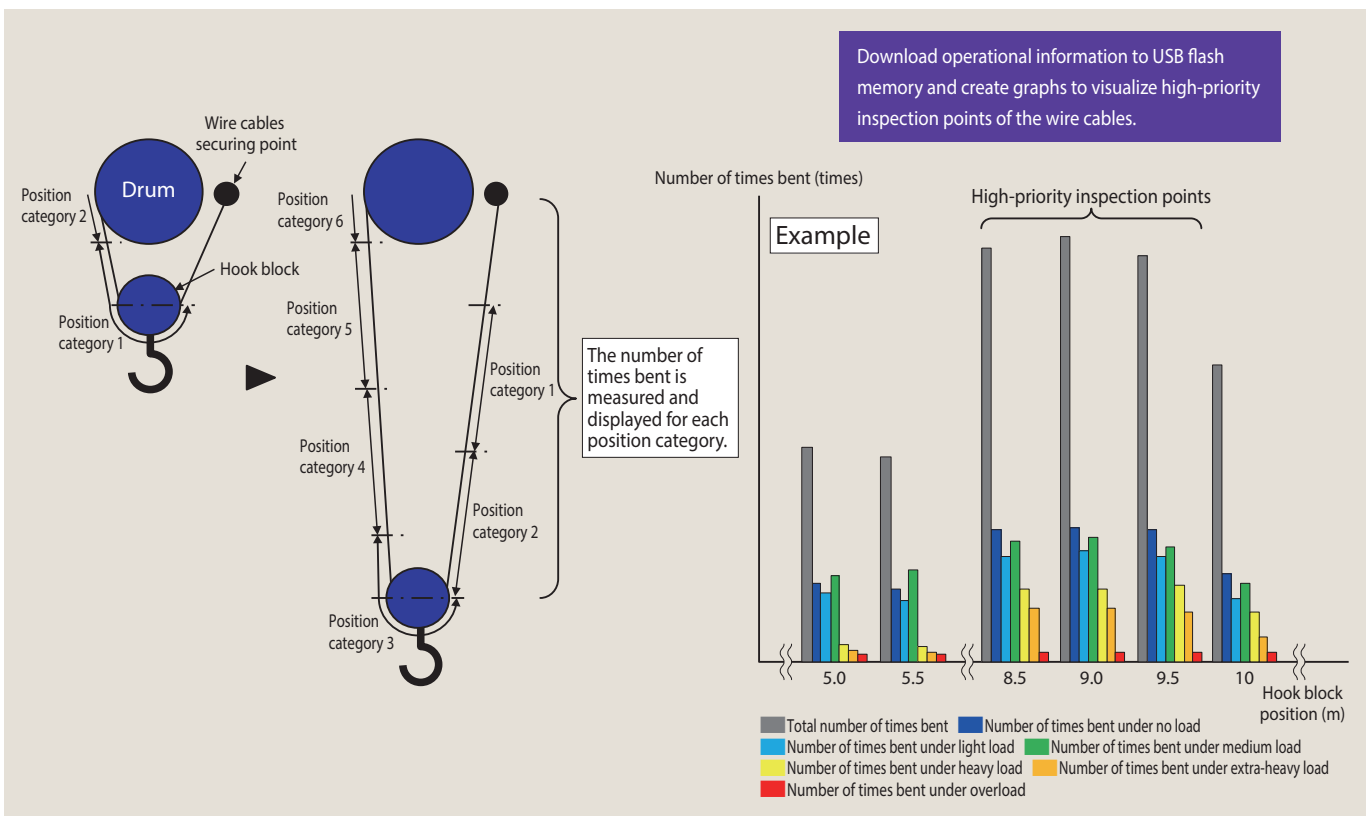

■ Improve ease of use

● External outputs (three terminals) standard

Relays (three units) are standard to output data such as operating status.

The outputs can be used for configuring a crane system.

Note: The external output terminals are not provided as part of the standard configuration in models designed for radio-based control. If you need external outputs for these models, order the optional external output function.

● External inputs (five terminals) standard

Input terminals (five terminals) are standard for use in providing control based on the traverse limit input.

External input voltage specification

Input detection voltage range	200 VAC, 50 Hz 200 VAC to 220 VAC, 60 Hz
-------------------------------	---

Notes: 1. Do not connect inductive loads.
2. The input phase must be the same as that of the operating voltage.

List of signals assignable to external input

No.	Input signal	Description of control provided by input
1	Hoisting operation input	Enables high-speed operation (pushbutton in second depressed position).
2	Traversal operation input	
3	Hoisting operation control	Disables operation or high-speed operation (pushbutton in second depressed position).
4	Traversal operation control	(Either one of the above settings can be selected by the user.)
5	Disable light-load high-speed operations	Disables light-load high-speed operation.
6	Electronic limit prohibit	Disables upper-/lower-limit stopping of the electronic limit function.
7	Disable speed change point	Disables up/down speed changes in the speed change point function
8	Hoist speed acceleration	Varies the operation speed steplessly based on input time.
9	Hoist speed deceleration	
10	Traversal speed acceleration	
11	Traversal speed deceleration	
12	Acceleration/deceleration initialization	Restores speeds changed by inputs No. 8 to No. 11 to default values.
13	Traverse limit	Controls operation based on traverse limit status.
14	Reference position setting	Resets the reference position based on input condition.
15	South operation input	Input of "south" signal
16	North operation input	Input of "north" signal
17	South/north high operation input	Input of "south/north high" signal
18	PB/radio-based control selection	Selection of use of pushbuttons on the pendant or radio-based control
19	Disable load sway suppression function	Disables control of load sway suppression function.
20	Disable lift-off operation assist function	Disables control of lift-off operation assist function.

List of signals assignable to external outputs

No.	Output signal	Signal output timing
1	Hoisting operation enabled	When hoisting operation is enabled
2	Hoisting abnormality detected	When hoisting-related abnormality is detected
3	Hoisting operation underway	When inverter frequency for hoisting is output
4	Light-load high-speed hoisting operation selected	During light-load high-speed operation
5	Hoisting overload prevention	When hoisting overload is detected
6	Electronic limit upper-limit stop	When electronic limit upper-limit stop point is reached
7	Electronic limit lower-limit stop	When electronic limit lower-limit stop point is reached
8	Up direction speed change point	When up direction speed change point is reached
9	Down direction speed change point	When down direction speed change point is reached
10	Mechanical limit 1st-stage operation	When mechanical limit 1st-stage operation is detected
11	Mechanical limit 2nd-stage operation	When mechanical limit 2nd-stage operation is detected
12	Traversal operation enabled	When traversal operation is enabled
13	Traversal abnormality detected	When traversal-related abnormality is detected
14	Traversal operation underway	When inverter frequency for traversal is output
15	Traverse limit operation	When traverse limit operation is detected
16	Operating status	When operation input is detected
17	Hook position output	When hoisting position reaches the set hoisting position
18	Maintenance alarm output	When maintenance alarm is output

Notes: 1. External inputs/outputs are not factory-set before shipment.
2. Normally Closed or Open can be selected for external outputs.
An open status results if Normally Closed is selected and no input signal is detected.

● Lift-off operation assist function

This function automatically pauses the hoisting operation if a load lift-off status is detected.

This allows confirmation of the sling condition while the load is stationary, thereby enhancing safety.

- Notes: 1. This control is disabled at the factory before shipment. Refer to the Operating Manual to enable the function.
2. The load value used to detect lift-off states that are 10% of the capacity or more. Note that deviations may occur due to the source voltage and motor temperature.
3. When this function is enabled, the operation is forcibly set to low speed while the lift-off status is being detected.
4. If the load is light and the lift-off status cannot be detected, the operation switches to the normal operation mode.
5. The position at which the lift-off status is detected is stored in memory and the lift-off status will not be redetected unless the load is lowered to a position below the stored position.

Basic slinging work (hoisting)

- (1) Select and check the slinging devices.
- (2) Attach the slinging devices to the load.
- (3) Attach the slinging eye to the hook.
- (4) Operate the hoist. Pause the operation if the wire cables become taut. Check the sling condition.
- (5) Operate the hoist to lift the load off the floor (about 10 cm to 20 cm above the floor) while observing the load condition to ensure that the load does not sway or tilt and that it is safe to continue hoisting.
- (6) Hoist the load to a safe height and then transport the load.

This step requires the lift-off operation assist function.

■ Instructions for special-order products

● Co-hoisting synchronization function

This function allows the simultaneous operation of two inverter hoists using a single operating button. There are two types of co-hoisting synchronization functions: a basic function for operation synchronization and an advanced function for position synchronization.

- Operation synchronization: This is the basic synchronization function.
- Position synchronization: This function provides a basic function and an automatic hook position adjustment function. The position synchronization provides horizontal hold control and position hold control.

Item	Operation synchronization	Position synchronization
Simultaneous start/stop operation of two hoists	○	○
Simultaneous stopping of two hoists when an alarm is tripped	○	○
Simultaneous stopping of two hoists at the time of overload detection	○	○
Synchronization of light-load high-speed operations of two hoists	○	○
Correction of operation speed if the load becomes unbalanced	○	○
Automatic load position adjustment operation	×	○

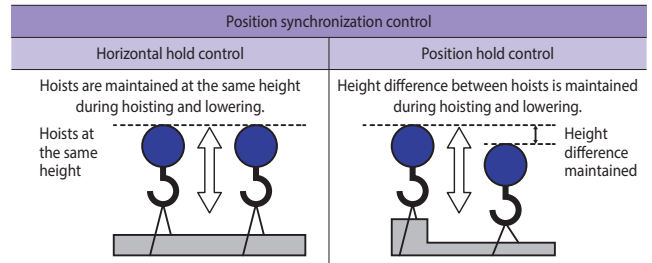

- Notes:
1. Adjust the settings so that the reference points are at the same position. If high precision is required, make sure the load is level before setting the reference points. Reset periodically to maintain performance.
 2. The difference in the elongation of the wire cables resulting from an offset load is not corrected automatically. The difference in motor slipping caused by an offset load is corrected automatically, but the difference in the elongation of the wire cables is not corrected. Perform slinging work carefully to ensure the appropriate balance.
 3. The length of the data communication cable connecting the hoists is subject to restrictions. For position synchronization, position information is exchanged between the hoists by data communication. Use a signal cable that does not exceed 40 m in length.

■ Linked/Single action operation selection: linked operation or Single action operation can be selected.

Please indicate your choice when placing your order.

Pushbuttons	Selector button	Hoisting	Traversal
(Link)(Sgl)	(Link)	Two hoists operate while linked.	Two hoists operate while linked.
	(Sgl)	Only the down pushbutton is enabled.	Only the down pushbutton is enabled.
(Link)(Sgl)(Sgl A)(Sgl B)	(Link)	Two hoists operate while linked.	Two hoists operate while linked.
		(Sgl A)	Only the down pushbutton is enabled.
	(Sgl B)	Hoist operations other than above	Hoist operations other than above

- Notes:
1. The device incorporates the "Link/Sgl" feature unless otherwise specified.
 2. Both the pendant pushbuttons and radio-based control pushbuttons support the co-hoisting synchronization function.
 3. Please contact us if you wish to use two connected hoists.

● External output function (6 points, 12 points, 18 points)

The number of output points for the external output function can be increased from the standard three points to six points, 12 points, or 18 points (selection is also possible for radio-based control).

● Multispeed (hoisting: 16-speed max. + light-load high-speed, traversal: eight-speed max.)

For hoisting, up to 16 speeds can be selected by combining up/down inputs and the four speed change inputs. For traversal, up to eight speeds can be selected by combining east/west inputs and the three speed change inputs.

Speed selection	Multispeed signal input				Light-load high-speed input
	4	3	2	1	
Multispeed 1	OFF	OFF	OFF	OFF	OFF
Multispeed 2	OFF	OFF	OFF	ON	OFF
Multispeed 3	OFF	OFF	ON	OFF	OFF
Multispeed 4	OFF	OFF	ON	ON	OFF
Multispeed 5	OFF	ON	OFF	OFF	OFF
Multispeed 6	OFF	ON	OFF	ON	OFF
Multispeed 7	OFF	ON	ON	OFF	OFF
Multispeed 8	OFF	ON	ON	ON	OFF
Multispeed 9	ON	OFF	OFF	OFF	OFF
Multispeed 10	ON	OFF	OFF	ON	OFF
Multispeed 11	ON	OFF	ON	OFF	OFF
Multispeed 12	ON	OFF	ON	ON	OFF
Multispeed 13	ON	ON	OFF	OFF	OFF
Multispeed 14	ON	ON	OFF	ON	OFF
Multispeed 15	ON	ON	ON	OFF	OFF
Multispeed 16	ON	ON	ON	ON	OFF
Light-load high-speed operation input	—				ON

- Notes:
1. Operation equipment must be provided and configured by the customer. Also, configure suitable input circuits using relays based on control equipment used.
 2. In cases in which up/down operation and light-load high-speed operational inputs are ON, regardless of the multispeed signal input status, the hoist operates at the speed suitable for determining whether to activate the light-load high-speed operation. If the load is determined to be light, the hoist operates in light-load high-speed operation mode.

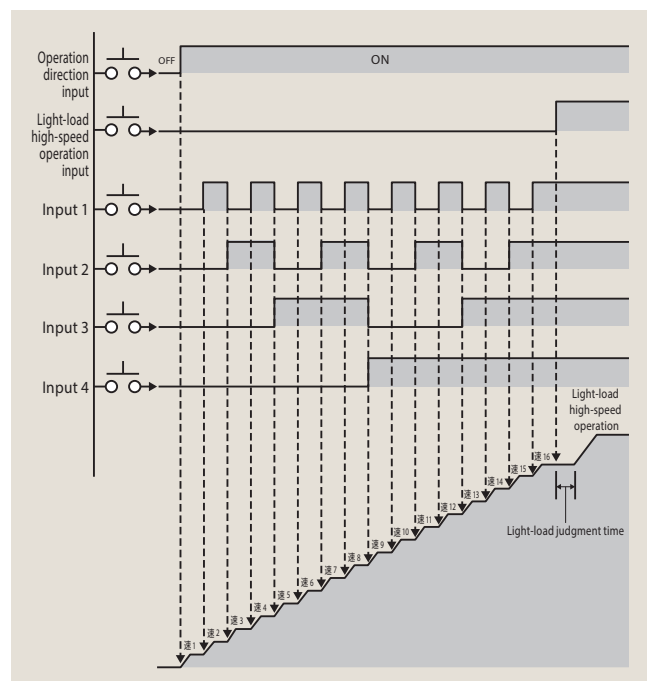

Specifications

400V Class

Series				Super V				
Capacity			t	1	2	3		
Hoist load			t	1.01	2.02	3.03		
Hoisting lift	Standard headroom type	Low hoist lift	m	6	6	6		
		High hoist lift	m	12	12	12		
	Low headroom type	Low hoist lift	m	6	6	6		
		High hoist lift	m	12	12	12		
	Double-rail type	Low hoist lift	m	–	–	6		
		High hoist lift	m	–	12	12		
Hoisting	Inverter	Speed (The figures in [] refer to light-load operation speeds.)		m / s	0.022 ~ 0.217[0.325]	0.017 ~ 0.167[0.25]	0.015 ~ 0.15[0.225]	
				m / min	1.3 ~ 13[19.5]	1.0 ~ 10[15]	0.9 ~ 9.0[13.5]	
		Motor output		kW	2.3	3.5	5.0	
		Rated current (200 VAC, 50 Hz/200 VAC, 60 Hz/220 VAC, 60 Hz)		A	8.0/7.0/7.0	10.5/9.5/9.5	14.0/13.0/12.0	
Traversing	Inverter	No. of poles of the motor		No. of poles	4	4	4	
		Speed		m / s	0.042 ~ 0.417	0.042 ~ 0.417	0.042 ~ 0.417	
				m / min	2.5 ~ 25	2.5 ~ 25	2.5 ~ 25	
		Standard headroom type/low headroom type	Motor output		kW	0.36	0.36	0.55
			Rated current (400 VAC, 50 Hz / 400VAC, 60 Hz / 440VAC, 60 Hz)		A	0.8/0.8/0.8	0.8/0.8/0.8	1.2/1.2/1.2
		Double-rail type	Motor output		kW	–	0.36	0.55
	Rated current (400 VAC, 50 Hz / 400VAC, 60 Hz / 440VAC, 60 Hz)		A	–	0.8/0.8/0.8	1.2/1.2/1.2		
	Commercial	Speed (50Hz/60Hz)		m / s	0.35/0.417	0.35/0.417	0.35/0.417	
				m / min	21/25	21/25	21/25	
		Standard headroom type/low headroom type	Motor output (50Hz/60Hz)		kW	0.30/0.36	0.30/0.36	0.45/0.55
			Rated current (400 VAC, 50 Hz / 400VAC, 60 Hz / 440VAC, 60 Hz)		A	1.1/1.0/1.0	1.1/1.0/1.0	1.4/1.1/1.2
		Double-rail type	Motor output (50Hz/60Hz)		kW	–	0.30/0.36	0.45/0.55
Rated current (400 VAC, 50 Hz / 400VAC, 60 Hz / 440VAC, 60 Hz)			A	–	1.1/1.0/1.0	1.4/1.1/1.2		
Wire cables	Standard headroom type		Standard headroom type	4	4	4		
			Low headroom type	4	4	4		
			Double-rail type	–	4	4		
	Low headroom type		No. of strands	2	2	2		
			Compositon	6 × Fi(29)-B	6 × Fi(29)-B	6 × Fi(29)-B		
			Diameter (mm)	φ 8	φ 11.2	φ 14		
	Double-rail type		No. of strands	4	4	4		
			Compositon	6 × W(19)-B	6 × Fi(29)-B	6 × Fi(29)-B		
			Diameter (mm)	φ 6.3	φ 8	φ 10		
Double-rail type		No. of strands	–	4	4			
		Compositon	–	6 × Fi(29)-B	6 × Fi(29)-B			
		Diameter (mm)	–	φ 8	φ 10			
Common specifications	Power supply (three-phase power supply)							
	Operation method							
	Operating voltage							
	Repetitive rating (rate of loading ≤ 0.63)	Hoisting	Frequency of starting					
			Duty factor					
		Traversing	Frequency of starting					
			Duty factor					
	Power supply method			Power is supplied via a cable. (If				
	Protection structure							
	Ambient temperature							
Humidity								
Paint color								
Compliance with standards								

Safety instructions for using the device

■ Standard specification products cannot be used in special environments, including the ones listed below.

Please contact us if you need a device that can be used in such environments.

1. Acid, alkali, and saline atmospheres; corrosive gas atmospheres
2. Environments with an ambient temperature above 40°C
3. Dusty environments
4. Environments in which the device is subject to splashing water
5. Environments with a risk of ignited explosion such as environments in which volatile dust or an organic solvent exists
6. Environments in which the device is used very frequently

■ If you using the device in a place with significant power supply noises, we recommend install a noise filter. Noise can cause malfunctions, including unexpected stoppages.

■ An inverter hoist will not stop immediately after you press the OFF pushbutton. The function that starts and stops the hoist to reduce impact requires a deceleration distance proportional to operating speed. Take deceleration distance when using the hoist. In particular, allow for sufficient deceleration distance when operating the hoist at high speed (above the rated speed) with the hoist carrying light load.

■ If the hoist is operated continuously for more than 1 minute at the lowest speed, the inverter's overheating protection function may activate to stop the hoist. If so, allow the hoist to remain stopped until the inverter cools (usually around 5 minutes or slightly longer) before restarting the hoist.

Hitachi Inverter Rope Hoist

series (type4)	V8 series (type4)					
	5	7.5	10	15	20	30
	5.07	7.65	10.2	15.2	20.3	30.4
	8	8	8	8	—	—
	12	12	12	12	12	—
	6	—	—	—	—	—
	11	—	—	—	—	—
	8	8	8	8	—	—
	12	12	12	12	12	12
	0.013 ~ 0.133[0.2]	0.012 ~ 0.12[0.18]	0.01 ~ 0.10[0.15]	0.01 ~ 0.10[0.15]	0.008 ~ 0.083[0.125]	0.006 ~ 0.055[0.083]
	0.8 ~ 8.0[12]	0.72 ~ 7.2[10.8]	0.6 ~ 6.0[9.0]	0.6 ~ 6.0[9.0]	0.5 ~ 5.0[7.5]	0.33 ~ 3.3[5.0]
	7.0	9.5	10.5	16	18	18
	19.0/17.0/16.0	24.0/22.0/22.0	25.0/25.0/22.0	34.0/34.5/32.0	38.0/37.0/36.0	41.0/40.0/36.0
	4	4	4	4	4	4
	0.042 ~ 0.417	0.028 ~ 0.283	0.028 ~ 0.283	0.028 ~ 0.283	0.028 ~ 0.283	0.028 ~ 0.283
	2.5 ~ 25	1.7 ~ 17	1.7 ~ 17	1.7 ~ 17	1.7 ~ 17	1.7 ~ 17
	0.75	0.56 × 2	0.56 × 2	0.84 × 2	0.84 × 2	—
	1.6/1.6/1.6	1.0 × 2/1.0 × 2/1.0 × 2	1.1 × 2/1.1 × 2/1.1 × 2	1.1 × 2/1.1 × 2/1.1 × 2	1.2 × 2/1.1 × 2/1.1 × 2	—
	0.55	0.55 × 2	0.55 × 2	0.55 × 2	0.55 × 2	0.84 × 2
	1.5/1.5/1.5	1.0 × 2/1.0 × 2/1.0 × 2	1.1 × 2/1.1 × 2/1.1 × 2	1.1 × 2/1.1 × 2/1.1 × 2	1.2 × 2/1.1 × 2/1.1 × 2	1.4 × 2/1.3 × 2/1.1 × 2
	0.35/0.417	0.233/0.283	0.233/0.283	—	—	—
	21/25	14/17	14/17	—	—	—
	0.63/0.75	0.47 × 2/0.56 × 2	0.47 × 2/0.56 × 2	—	—	—
	1.6/1.3/1.4	2.1 × 2/1.7 × 2/1.7 × 2	2.1 × 2/1.7 × 2/1.7 × 2	—	—	—
	0.45/0.55	0.45 × 2/0.55 × 2	0.45 × 2/0.55 × 2	—	—	—
	1.5/1.2/1.3	1.4 × 2/1.0 × 2/1.2 × 2	1.4 × 2/1.0 × 2/1.2 × 2	—	—	—
	4	6	6	4	4	—
	4	—	—	—	—	—
	4	4	4	4	4	4
	4	4	4	4	4	—
	6 × Fi(29)-B	6 × Fi(29)-B	6 × Fi(29)-B	6 × Fi(29)-B	6 × Fi(29)-B	—
	φ 12.5	φ 14	φ 16	φ 20	φ 22.4	—
	4	—	—	—	—	—
	6 × Fi(29)-B	—	—	—	—	—
	φ 12.5	—	—	—	—	—
	4	4	4	4	4	8
	6 × Fi(29)-B	6 × Fi(29)-B	6 × Fi(29)-B	6 × Fi(29)-B	6 × Fi(29)-B	6 × Fi(29)-B
	φ 12.5	φ 14	φ 16	φ 20	φ 22.4	φ 20

380VAC, 50Hz / 400VAC, 50Hz / 415VAC, 50Hz
380VAC, 60Hz / 400VAC, 60Hz / 440VAC, 60Hz / 460VAC, 60Hz / 480VAC, 60Hz

Pushbuttons on the pendant

Eight pushbuttons designed to be operated by an operator standing on the floor (on, off, up, down, left, right, forward and reverse)

* The pushbuttons with two depressed points are as follows:

Inverter-based control of hoisting and traversal: up, down, left, right, forward and reverse

Inverter-based control of hoisting only: up and down

Inverter-based control of traversal only: left and right

200 VAC

400 times per hour

40%ED

400 times per hour

40%ED

you are using a collector/bus duct or other contact-type current collector, please be sure to use a double-trolley system.)

JIS C0920 IP44

* For outdoor use, please provide a covered refuge bay so that the hoist is not exposed to rain.

* The IP rating is for the motor section and the control panel.

-10 to +40°C (without freezing)

90% or less (without condensation)

Munsell 2.5B, 2.5/1

A crane structure standard

Specifications

200V Class

Series				Super V series (type4)							
Capacity			t	1	2	2.8	3				
Hoist load			t	1.01	2.02	2.83	3.03				
Hoist lift	Standard headroom type	Low hoist lift	m	6	6	6	6				
		High hoist lift	m	12	12	12	12				
	Low headroom type	Low hoist lift	m	6	6	6	6				
		High hoist lift	m	12	12	12	12				
	Double-rail type	Low hoist lift	m	—	—	6	6				
		High hoist lift	m	—	12	12	12				
Hoist-ing	Inverter	Speed (The figures in [] refer to light-load operation speeds.)		m/s	0.022~0.217[0.325]	0.017~0.167[0.25]	0.015~0.15[0.225]	0.015~0.15[0.225]			
				m/min	1.3~13[19.5]	1.0~10[15]	0.9~9.0[13.5]	0.9~9.0[13.5]			
		Motor output		kW	2.3	3.5	4.8	5.0			
		Rated current (200 VAC, 50 Hz/200 VAC, 60 Hz/220 VAC, 60 Hz)		A	14.0/13.5/12.5	20.0/18.0/16.0	25.0/23.0/21.0	26.0/24.0/22.0			
Tra-versing	Inverter	No. of poles of the motor		No. of poles	4	4	4	4			
		Speed		m/s	0.042~0.417	0.042~0.417	0.042~0.417	0.042~0.417			
				m/min	2.5~25	2.5~25	2.5~25	2.5~25			
		Standard headroom type/ low headroom type	Motor output		kW	0.36	0.36	0.55	0.55		
			Rated current (200 VAC, 50 Hz / 200VAC, 60 Hz / 220VAC, 60 Hz)		A	1.6/1.6/1.6	1.6/1.6/1.6	2.5/2.5/2.5	2.5/2.5/2.5		
		Double-rail type	Motor output		kW	—	0.36	0.55	0.55		
	Rated current (200 VAC, 50 Hz / 200VAC, 60 Hz / 220VAC, 60 Hz)		A	—	1.6/1.6/1.6	2.5/2.5/2.5	2.5/2.5/2.5				
	Commercial	Speed (50Hz/60Hz)		m/s	0.35/0.417	0.35/0.417	0.35/0.417	0.35/0.417			
				m/min	21/25	21/25	21/25	21/25			
		Standard headroom type/ low headroom type	Motor output (50Hz/60Hz)		kW	0.30/0.36	0.30/0.36	0.45/0.55	0.45/0.55		
			Rated current (200 VAC, 50 Hz / 200VAC, 60 Hz / 220VAC, 60 Hz)		A	2.0/1.6/1.8	2.0/1.6/1.8	2.7/2.0/2.3	2.7/2.0/2.3		
		Double-rail type	Motor output (50Hz/60Hz)		kW	—	0.30/0.36	0.45/0.55	0.45/0.55		
Rated current (200 VAC, 50 Hz / 200VAC, 60 Hz / 220VAC, 60 Hz)			A	—	2.0/1.6/1.8	2.7/2.0/2.3	2.7/2.0/2.3				
No. of poles of the motor			Standard headroom type	4	4	4	4				
			Low headroom type	4	4	4	4				
			Double-rail type	—	4	4	4				
Wire cables			Standard headroom type	No. of strands	2	2	2	2			
				Compositon	6×Fi(29)-B	6×Fi(29)-B	6×Fi(29)-B	6×Fi(29)-B			
			Low headroom type	No. of strands	4	4	4	4			
				Compositon	6×W(19)-B	6×Fi(29)-B	6×Fi(29)-B	6×Fi(29)-B			
			Double-rail type	No. of strands	—	4	4	4			
				Compositon	—	6×Fi(29)-B	6×Fi(29)-B	6×Fi(29)-B			
			Diameter (mm)	—	φ8	φ10	φ10				
Common specifications				Power supply (three-phase power supply)							
				Operation method							
				Operating voltage							
				Repetitive rating (rate of loading ≤ 0.63)	Hoisting	Frequency of starting					
						Duty factor					
					Traversing	Frequency of starting					
						Duty factor					
				Power supply method				Power is supplied via a cable. (If you			
				Protection structure							
				Ambient temperature							
				Humidity							
				Paint color							
				Compliance with standards							

Safety instructions for using the device

- Standard specification products cannot be used in special environments, including the ones listed below. Please contact us if you need a device that can be used in such environments.
 1. Acid, alkali, and saline atmospheres; corrosive gas atmospheres
 2. Environments with an ambient temperature above 40°C
 3. Dusty environments
 4. Environments in which the device is subject to splashing water
 5. Environments with a risk of ignited explosion such as environments in which volatile dust or an organic solvent exists
 6. Environments in which the device is used very frequently
- If you using the device in a place with significant power supply noises, we recommend install a noise filter. Noise can cause malfunctions, including unexpected stoppages.

- An inverter hoist will not stop immediately after you press the OFF pushbutton. The function that starts and stops the hoist to reduce impact requires a deceleration distance proportional to operating speed. Take deceleration distance when using the hoist. In particular, allow for sufficient deceleration distance when operating the hoist at high speed (above the rated speed) with the hoist carrying light load.
- If the hoist is operated continuously for more than 1 minute at the lowest speed, the inverter's overheating protection function may activate to stop the hoist. If so, allow the hoist to remain stopped until the inverter cools (usually around 5 minutes or slightly longer) before restarting the hoist.

Hitachi Inverter Rope Hoist

				V8 series (type4)		
	5	7.5	10	15	20	30
	5.07	7.65	10.2	15.2	20.3	30.4
	8	8	8	8	—	—
	12	12	12	12	12	—
	6	—	—	—	—	—
	11	—	—	—	—	—
	8	8	8	8	—	—
	12	12	12	12	12	12
	0.013~0.133[0.2]	0.012~0.12[0.18]	0.01~0.10[0.15]	0.01~0.10[0.15]	0.008~0.083[0.125]	0.006~0.055[0.083]
	0.8~8.0[12]	0.72~7.2[10.8]	0.6~6.0[9.0]	0.6~6.0[9.0]	0.5~5.0[7.5]	0.33~3.3[5.0]
	7.0	9.5	10.5	16	18	18
	35.0/34.0/30.0	46.0/43.0/40.0	54.0/51.0/46.0	70.0/69.0/63.0	78.0/77.0/71.0	82.0/81.0/73.0
	4	4	4	4	4	4
	0.042~0.417	0.028~0.283	0.028~0.283	0.028~0.283	0.028~0.283	0.028~0.283
	2.5~25	1.7~17	1.7~17	1.7~17	1.7~17	1.7~17
	0.75	0.56×2	0.56×2	0.84×2	0.84×2	—
	2.8/2.8/2.8	2.2×2/2.1×2/2.1×2	2.2×2/2.1×2/2.1×2	1.8×2/1.7×2/1.7×2	1.8×2/1.7×2/1.7×2	—
	0.55	0.55×2	0.55×2	0.55×2	0.55×2	0.84×2
	2.6/2.6/2.6	1.7×2/1.5×2/1.4×2	1.7×2/1.5×2/1.4×2	1.7×2/1.5×2/1.4×2	2.2×2/1.8×2/1.8×2	3.3×2/2.7×2/2.7×2
	0.35/0.417	0.233/0.283	0.233/0.283	—	—	—
	21/25	14/17	14/17	—	—	—
	0.63/0.75	0.47×2/0.56×2	0.47×2/0.56×2	—	—	—
	3.0/2.3/2.6	3.7×2/2.6×2/3.0×2	3.7×2/2.6×2/3.0×2	—	—	—
	0.45/0.55	0.45×2/0.55×2	0.45×2/0.55×2	—	—	—
	2.9/2.2/2.4	2.7×2/2.0×2/2.3×2	2.7×2/2.0×2/2.3×2	—	—	—
	4	6	6	4	4	—
	4	—	—	—	—	—
	4	4	4	4	4	4
	4	4	4	4	4	—
	6×Fi(29)-B	6×Fi(29)-B	6×Fi(29)-B	6×Fi(29)-B	6×Fi(29)-B	—
	φ12.5	φ14	φ16	φ20	φ22.4	—
	4	—	—	—	—	—
	6×Fi(29)-B	—	—	—	—	—
	φ12.5	—	—	—	—	—
	4	4	4	4	4	8
	6×Fi(29)-B	6×Fi(29)-B	6×Fi(29)-B	6×Fi(29)-B	6×Fi(29)-B	6×Fi(29)-B
	φ12.5	φ14	φ16	φ20	φ22.4	φ20

200V 50/60Hz, 220V 60Hz

Pushbuttons on the pendant

Eight pushbuttons designed to be operated by an operator standing on the floor (on, off, up, down, left, right, forward and reverse)

* The pushbuttons with two depressed points are as follows:

Inverter-based control of hoisting and traversal: up, down, left, right, forward and reverse

Inverter-based control of hoisting only: up and down

Inverter-based control of traversal only: left and right

200 VAC or 220 VAC (depending on power supply voltage)

400 times per hour

40%ED

400 times per hour

40%ED

are using a collector/bus duct or other contact-type current collector, please be sure to use a double-trolley system.)

JIS C0920 IP44

* For outdoor use, please provide a covered refuge bay so that the hoist is not exposed to rain.

* The IP rating is for the motor section and the control panel.

-10 to +40° C (without freezing)

90% or less (without condensation)

Munsell 2.5B, 2.5/1

A crane structure standard

Standard headroom-type hoists

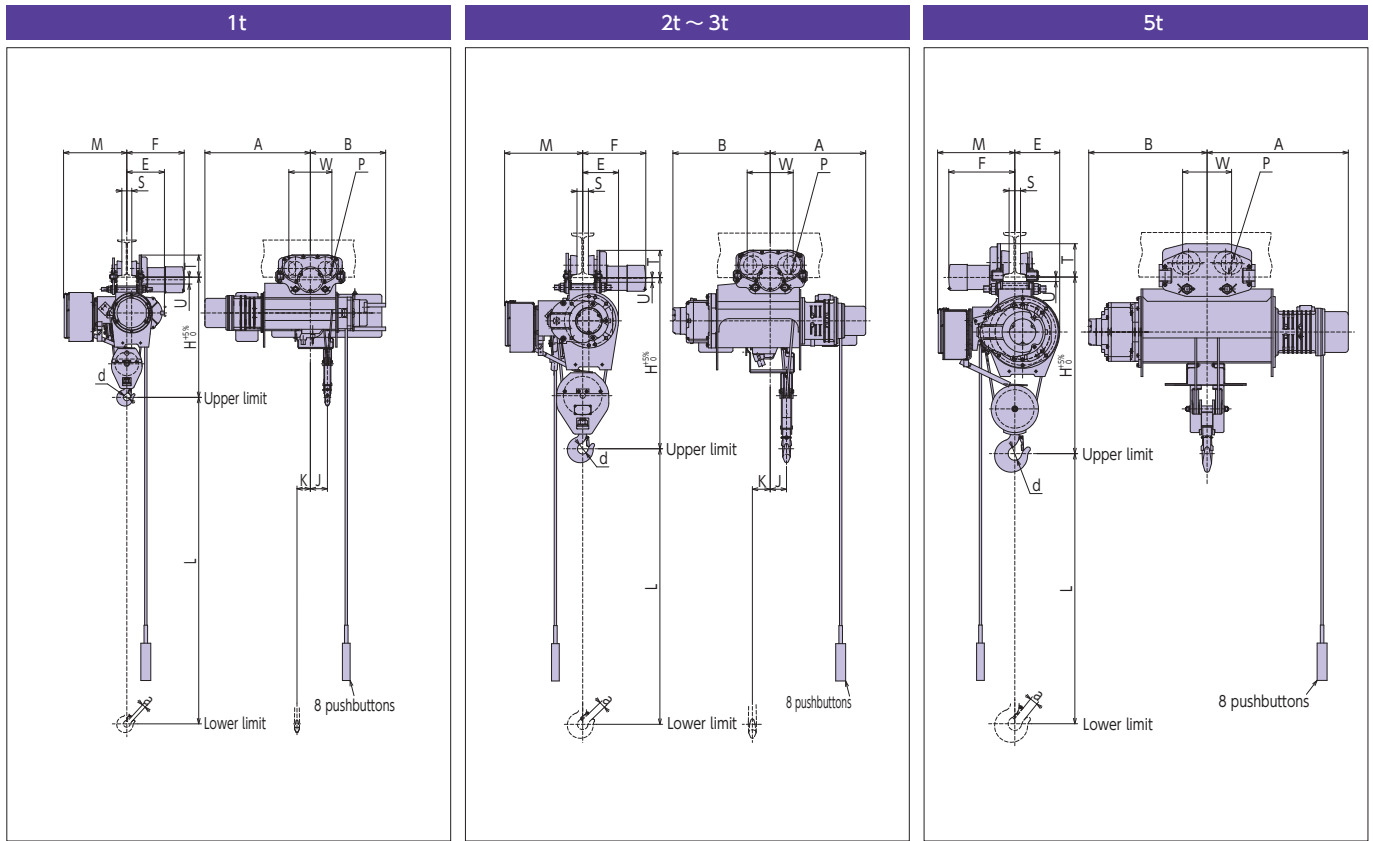

Series		Super V series (type4)											
Type	Inverter-based control of hoisting and traversal	1M-T65-W4	1HM-T65-W4	2M-T75-W4	2HM-T75-W4	2.8M-T65-W4	2.8HM-T65-W4	3M-T65-W4	3HM-T65-W4				
	Inverter-based control of hoisting only	1M-T65-V4	1HM-T65-V4	2M-T75-V4	2HM-T75-V4	2.8M-T65-V4	2.8HM-T65-V4	3M-T65-V4	3HM-T65-V4				
Capacity (t)		1		2		2.8		3					
Approx. dimensions (mm)	L	6,000	12,000	6,000	12,000	6,000	12,000	6,000	12,000				
	H	790		985		1,115		1,115					
	A	545	715	620	630	610	645	610	645				
	B	475	510	435	615	510	660	510	665				
	M	430		485		530		530					
	E	255		220		245		245					
	W	200/290		200/290		230/310		230/310					
	G	-		-		-		-					
	K	20	90	30	110	35	120	35	120				
	J	85	115	75	100	80	110	80	110				
	d	45		56		71		71					
	P	96/96		96/96		128/128		128/128					
	a	23		36		42		42					
Min. curve radius (m)		3.5/1.5		4.5/1.8		5.0/2.0		5.0/2.0					
Dimensions with respect to I-beam (mm)		F	S	T	U	F	S	T	U	F	S	T	U
200×100×7		374	42	148	47/42	378	42	148	42/42				
250×125×7.5		387	67	151	44/39	391	67	151	39/39	417	52	177	38/38
300×150×11.5		400	92	160	35/30	404	92	160	30/30	430	77	187	28/28
450×175×11										443	102	185	30/30
600×190×13													
Approx. weight (kg)		200		220		295		345		405		435	

- Notes:
- Specifications in the table are common to 200V and 400V classes.
 - Dimensions W and P indicate [drive side/driven side].
 - Dimension U indicates [low hoist lift/high hoist lift] ([High hoist lift] only for 20t).
 - The min. curve radius indicates [inverter-based control of traversal/commercial traversal] ([Inverter based control of traversal] only for 15t and 20t).
 - Unless otherwise specified by the customer, the device delivered will be compatible with I-beams with the dimensions shown in the colored columns.
 - The device contains electronic components. Be sure to install a buffering mechanism or buffering material on the stoppers for longitudinal and traversing movement.

Hitachi Inverter Rope Hoist

7.5t, 10t

15t, 20t

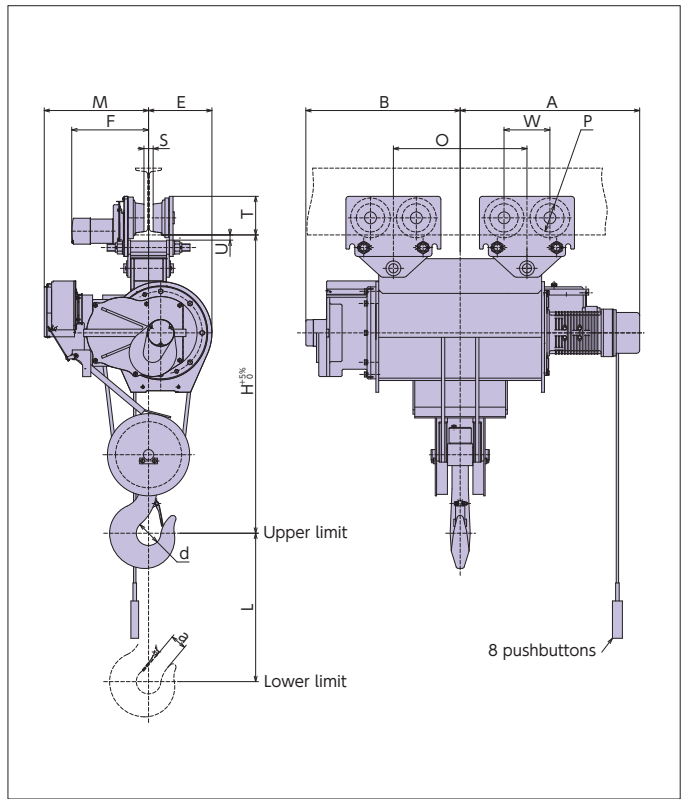
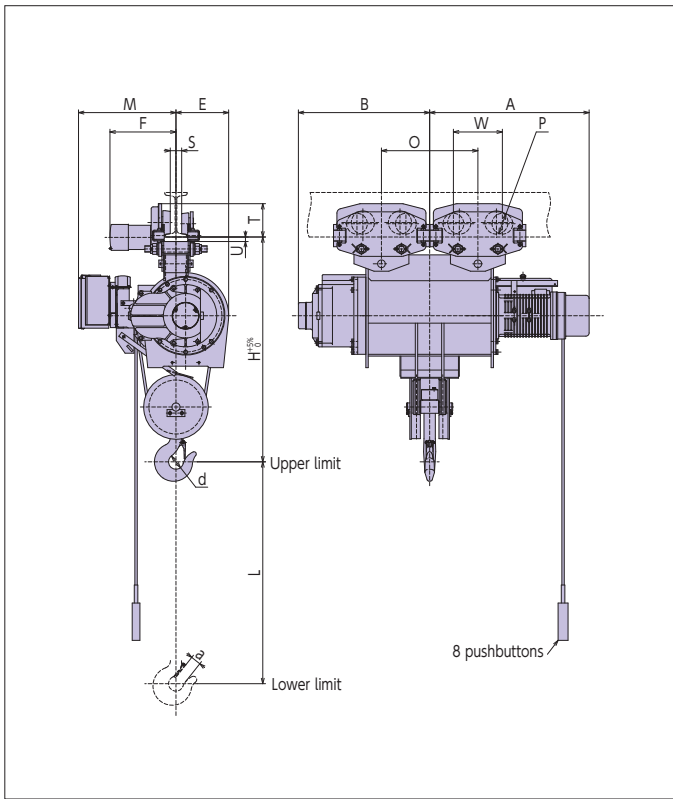

										V8 series (type4)									
5M-T55-W4		5HM-T55-W4		7.5M-T55-W4		7.5HM-T55-W4		10M-T55-W4		10HM-T55-W4		15M-T88-W4		15HM-T88-W4		20HM-T88-W4			
5M-T55-V4		5HM-T55-V4		7.5M-T55-V4		7.5HM-T55-V4		10M-T55-V4		10HM-T55-V4		-		-		-			
5				7.5				10				15				20			
8,000		12,000		8,000		12,000		8,000		12,000		8,000		12,000		12,000			
1,190				1,345				1,515				1,865				2,010			
845		955		1,075		1,150		1,075		1,150		1,060		1,160		1,210			
690		800		830		905		885		960		950		990		1,040			
525				640				670				705				705			
305				315				355				427				427			
250/330				230/310				250/330				309/309				309/309			
-				560		760		650		786		820				900			
-				-				-				-				-			
90				100				100				130				165			
156/140				128/128				156/140				190/190				190/190			
58				69				69				86				108			
Straight line/3.0				Straight line/Straight line				Straight line/Straight line				Straight line				Straight line			
F	S	T	U	F	S	T	U	F	S	T	U	F	S	T	U	F	S	T	U
450	77	225	30/30	440	77	186	28/28	450	77	225	30/30								
463	102	223	32/32	453	102	184	30/30	460	102	225	30/30	524	62	280	30/30	524	62	280	30
				461	117	189	25/25	468	117	230	25/25	532	77	285	25/25	532	77	285	25
710		775		970		1,030		1,280		1,340		2,140		2,390		2,740			

■ Double-rail-type hoists

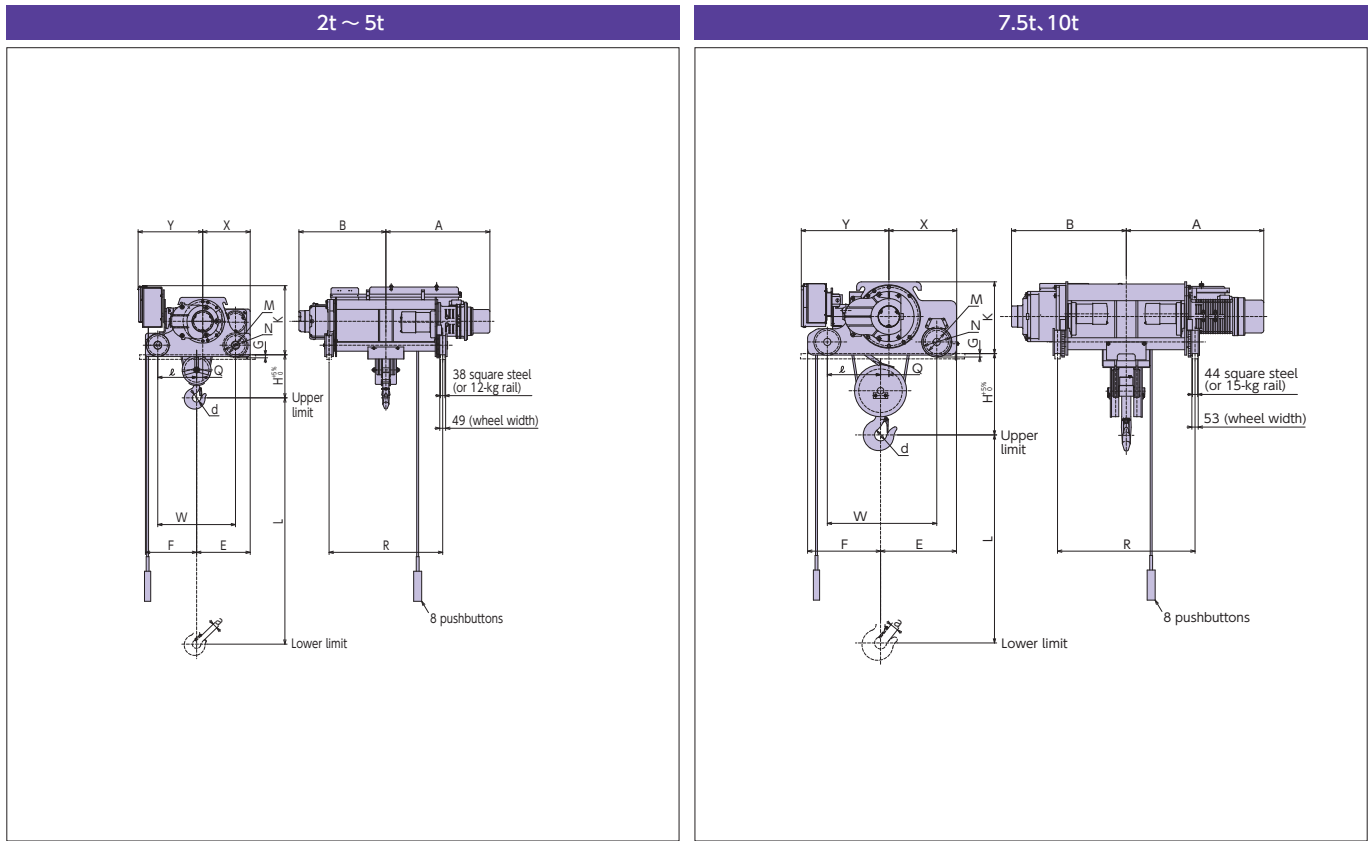

Series		Super V series (type4)							
Type	Inverter-based control of hoisting and traversal	2HD-T55-W4	2.8D-T55-W4	2.8HD-T55-W4	3D-T55-W4	3HD-T55-W4	5D-T55-W4	5HD-T55-W4	
	Inverter-based control of hoisting only	2HD-T55-V4	2.8D-T55-V4	2.8HD-T55-V4	3D-T55-V4	3HD-T55-V4	5D-T55-V4	5HD-T55-V4	
Capacity (t)		2	2.8		3		5		
Approx. dimensions (mm)	L	12,000	6,000	12,000	6,000	12,000	8,000	12,000	
	H	310	360		360		560		
	K	520	580		580		590		
	R	900	650	950	650	950	900	1,150	
	E	425	450		450		550		
	F	455	430		430		530		
	W	650	650		650		850		
	X	385	399		399		495		
	Y	515	545		545		605		
	A	835	710	870	710	870	845	955	
	B	675	570	730	570	730	690	800	
	φ d	56	71		71		90		
	Q	40	51		51		55		
	ℓ	350	325		325		425		
	φ M	160	160		160		160		
φ N	190	190		190		190			
G	26	26		26		26			
a	36	42		42		58			
Rail used		38 square steel or 12-kg rail							
Wheel width (mm)		49							
Approx. weight (kg)		400	440	510	440	510	695	765	

Note: 1. Specifications in the table are common to 200V and 400V classes.
 2. As the device contains electronic components, be sure to install a buffering mechanism or buffering material on the stoppers for the longitudinal and traversal.

Hitachi Inverter Rope Hoist

15t, 20t

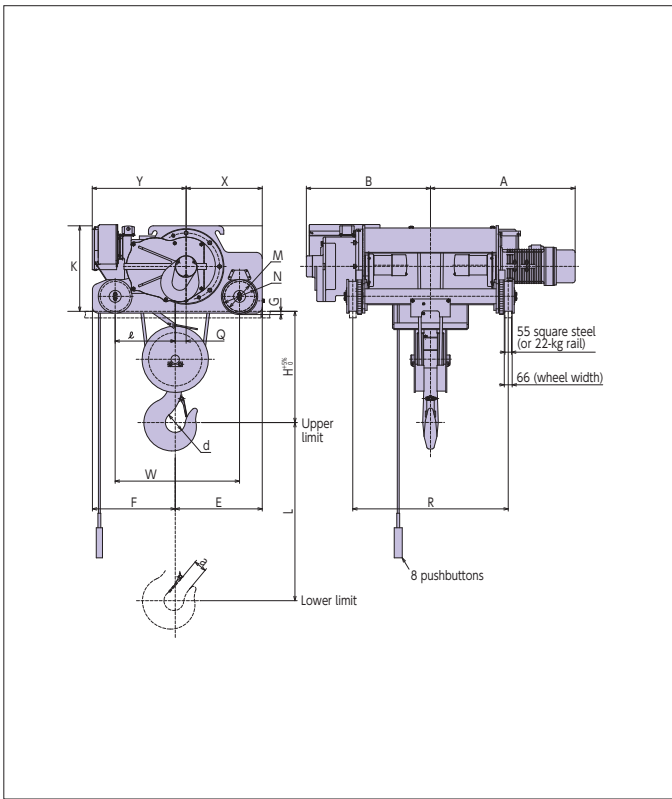

30t

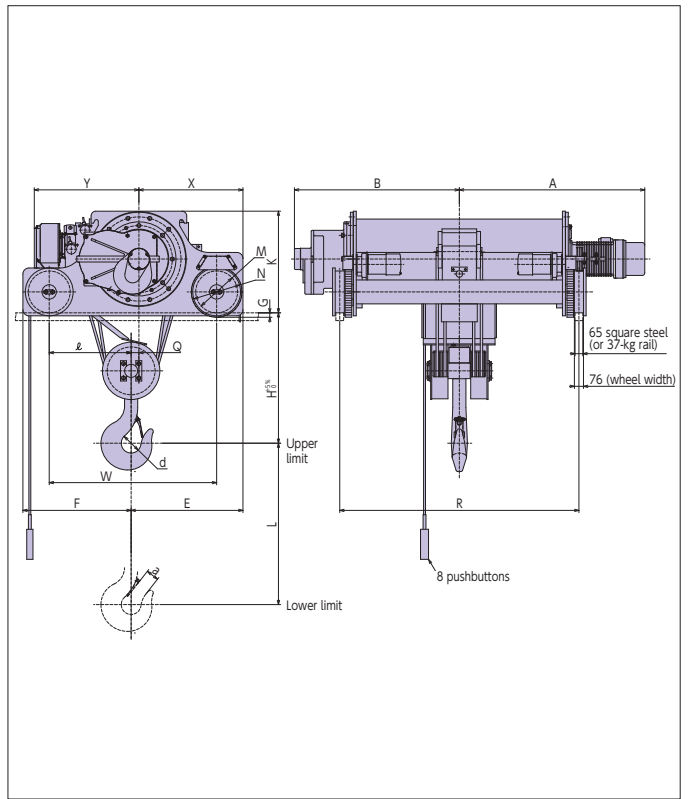

V8 series (type4)									
	7.5D-T55-W4	7.5HD-T55-W4	10D-T55-W4	10HD-T55-W4	15D-T88-W4	15HD-T88-W4	20HD-T88-W4	30HD-T88-W4	
	7.5D-T55-V4	7.5HD-T55-V4	10D-T55-V4	10HD-T55-V4	—	—	—	—	
	7.5			10		15		20	
	8,000	12,000	8,000	12,000	8,000	12,000	12,000	12,000	
		515		680		785		930	
		600		600		730		730	
	1,000	1,150	1,000	1,150	1,000	1,200	1,300	2,000	
		615		650		740		740	
		605		615		700		700	
		865		915		1,040		1,040	
		548		580		640		640	
		730		735		780		780	
	1,075	1,150	1,075	1,150	1,060	1,160	1,210	1,560	
	830	905	885	960	960	990	1,040	1,390	
		100		100		130		165	
		67		70		89		91	
		433		445		505		505	
		195		195		250		250	
		225		225		282		282	
		29		29		28		28	
		69		69		86		108	
	44 square steel or 15-kg rail				55 square steel or 22-kg rail			65 square steel or 37-kg rail	
	53				66			76	
	1,100	1,170	1,310	1,400	1,950	2,100	2,250	4,200	

Low headroom-type hoists

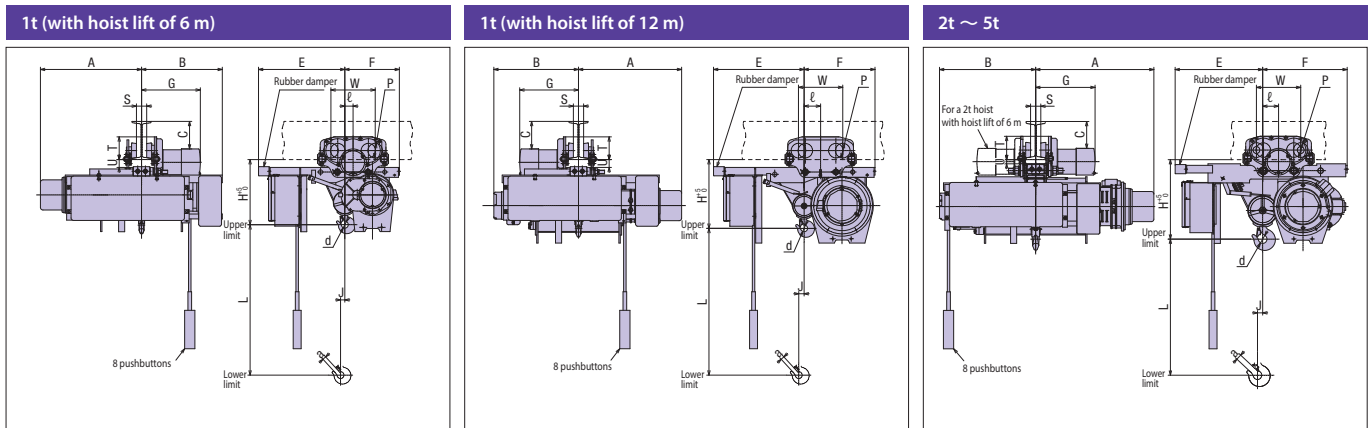

Type	Inverter-based control of hoisting and traversal				Inverter-based control of hoisting only																																			
	1L-T ₅₅ -W ₄	1HL-T ₅₅ -W ₄	2L-T ₅₅ -W ₄	2HL-T ₅₅ -W ₄	2.8L-T ₅₅ -W ₄	2.8HL-T ₅₅ -W ₄	3L-T ₅₅ -W ₄	3HL-T ₅₅ -W ₄	5L-T ₅₅ -W ₄	5HL-T ₅₅ -W ₄																														
Capacity (t)	1				2				2.8				3				5																							
Approx. dimensions (mm)	L	6,000	12,000	6,000	12,000	6,000	12,000	6,000	12,000	6,000	12,000	6,000	12,000	6,000	12,000	6,000	11,000																							
	H	425	450	515	520	600	650	600	650	600	650	600	650	600	650	810																								
	A	665	675	705	775	750	795	750	795	750	795	750	795	845	955																									
	B	530	560	605	635	620	700	620	700	620	700	620	700	690	800																									
	M	565	595	595	575	635	675	635	675	635	675	635	675	635	705																									
	E	360	465	480	560	575	660	575	660	575	660	575	660	575	675																									
	W	200/290				200/290				230/310				230/410																										
	K	28	35	42	34	46	50	46	50	46	50	46	50	46	50	35																								
	J	45				56				71				71																										
	d	96/96				96/96				128/128				128/128																										
P	23				36				42				42																											
a	54	108	85	104	100	99	100	99	100	99	100	99	100	99	89																									
Min. curve radius (m)	3.5/1.5				4.5/1.8				5.0/2.0				3.5																											
Dimensions with respect to I-beam (mm)	G	S	T	U	G	S	T	U	G	S	T	U	G	S	T	U																								
200x100x7	374	42	148	52	378	42	148	32					417	52	177	28																								
250x125x7.5	387	67	151	49	391	67	151	29	417	52	177	28	417	52	177	28																								
300x150x11.5	400	92	160	40	404	92	160	20	430	77	187	18	430	77	187	18																								
450x175x11									443	102	185	20	443	102	185	20																								
Approx. weight (kg)	235				315				330				460				455				620				455				620				765				835			

- Notes:
- Specifications in the table are common to 200V and 400V classes.
 - Dimensions W and P indicate [drive side/driven side].
 - The min. curve radius indicates [inverter-based control of traversal/commercial traversal].
 - Unless otherwise specified by the customer, the device delivered will be compatible with I-beams with the dimensions shown in the colored columns.
 - The device contains electronic components. Be sure to install a buffering mechanism or buffering material on the stoppers for longitudinal and traversing movement.
 - The rubber damper is standard on the control panel mounting surface.

Inverter unit for saddles N-1C₄, N-5C₄, N-10S₄, N-10C₄, N-30S₄, N-30C₄

Note: Please contact us for more information about N-10S₄, N-10C₄, N-30S₄, N-30C₄.

Load sway suppression function standard

The load sway suppression function can be used when combined with a Hitachi inverter hoist (Super V4).

(For detail of the load sway suppression function, see page 1.)

The load sway suppression function is standard in products produced in and after October 2017. To check whether your device is equipped with the function, refer to the decorative nameplate on the control panel surface.

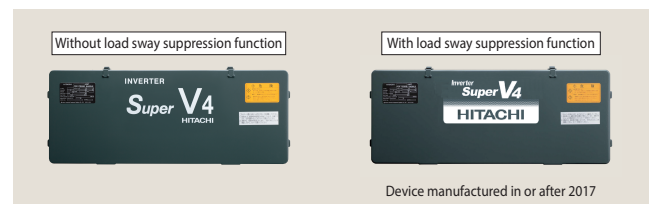

Hitachi Inverter Rope Hoist

● Features

The unit is ready to use as soon as the installation of the unit and the wiring is completed.

The unit comes with a circuit breaker and a main power supply MgSW as standard components. There is no need to prepare a shared protection panel.

A compact inverter unit that is easy to install

The compact and easy-to-install inverter unit houses all the components in the panel.

Dramatically reduces impact on and the pendular motion of the suspended load

The starting and stopping impact reduction function ensures smooth acceleration and deceleration, thereby minimizing impact on and the pendular motion of the suspended load during travel.

Speed can be changed to achieve efficient operations.

The travel speed can be set in two stages within 10% of the rated speed.

Allows selection of optimal line operation speed.

For some saddles, 150% or 200% speed can be set.

Easy installation to a crane system

Equipped with a relay (one unit) that outputs data indicating operating status

Equipped with two sets of external output circuits in addition the operational inputs

- Can be used for travel limit input

Improved ease of maintenance

Reduced impact also mitigates impact on the mechanical parts of the saddle, thereby extending the service lives of consumable parts.

Equipped with an 8-digit 7-segment LED display that provides information (such as number of times started) at a glance.

Operational data can be saved to an USB flash drive.

- Operational data are output as text data.
- No USB flash drive is supplied.

■ Dimensions

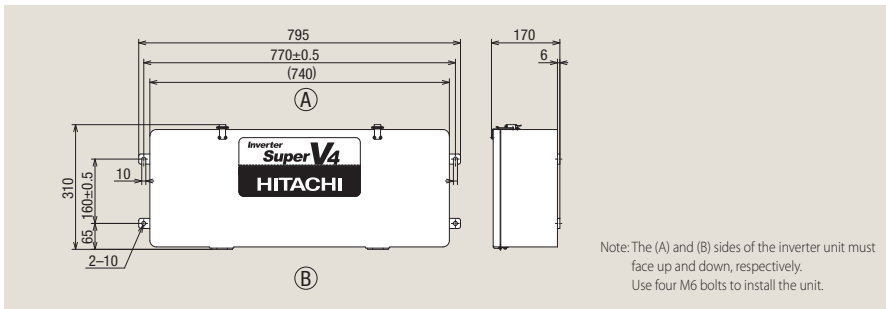

■ Schematic diagram of electrical wiring

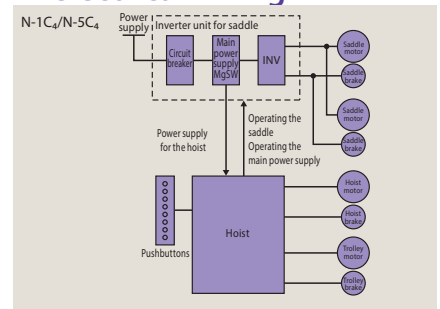

■ Table of specifications

Select the appropriate model based on hoist and circuit breaker capacity.

Type	N-1C ₄	N-5C ₄
Applicable hoists	1t	2~5t
Circuit breaker	S-50EB (20A) (built in)	S-50EB (50A) (built in)
Main power supply switch	HS50 (50A) (built in)	
Power supply	200 V class: 3-phase, 200 VAC, 50/60 Hz or 220 VAC, 60Hz 400 V class: 3-phase, 380 VAC, 50/60 Hz; 400 VAC, 50/60 Hz; or 220 VAC, 60Hz	
Power supply system	Power is supplied via cable/trolley cable (use a double-trolley system.)	
Rated speed range	0.0417 m/s to 0.417 m/s (2.5 m/min to 25 m/min) (The factory-set default values are the lowest speed [6 Hz] and highest speed [60 Hz].)	
Repetitive rating	With two 5%ED duty factor and a starting frequency of 250 times per hour For use at 200% of the rated speed: 25%ED duty factor and a starting frequency of 110 times per hour For use at 150% of the rated speed: 25%ED duty factor and a starting frequency of 150 times per hour	
Operation method	Two depressed-position pushbutton inputs (direction signal [examples: south, north] and high-speed signal inputs) supported. 1st depressed position: low speed; 2nd depressed position: high speed	
Protection structure	JIS C0920, IP44 Note: For outdoor use, please install a roof, etc. over the unit.	
Ambient temperature	-10 to +40°C (without freezing)	
Humidity	90% or less (without condensation)	
Paint color	Munsell 2.5B, 2.5/1	
Other	You can attach electromagnetic contactors for alarm and illumination. Operating status detection and abnormal condition detection functions are built into the unit.	
Approx. weight	200 V class: 17 kg 400 V class: 19 kg	
Installation method	Screw the inverter unit on the crane using the mounting holes.	

■ Applicable range of saddle speed increase

Saddle type	Max. output frequency
THs-10	120Hz
THs-28	120Hz
THs-30	120Hz
THL6-30	120Hz
THs-56	90Hz
THL6-56	90Hz
TLMs-10	90Hz
TLM6-28	90Hz
TLM6-30	90Hz
TLM6-45	90Hz

Network

Hitachi Industrial Equipment Systems Co., Ltd. meets customers' needs through the total network which can supply speedy design, production, sales, service and engineering for industrial equipment and systems.

Global Sales Network



Asia & Oceania

China

Hitachi Industrial Equipment Systems (China) Co., Ltd.
(Shanghai Office)
Room2201, Rui Jin Building, No.205
Maoming Road(S) Shanghai 200020
TEL : +86 (21) 5489-2378
FAX : +86 (21) 3356-5070

(Beijing Office)

Room1420, Beijing Fortune Building,
No.5 Dong San Huan Bei Road,
Chao Yang District, Beijing 100004
TEL : +86 (10) 6590-8180
FAX : +86 (10) 6590-8189

(Guangzhou Office)

Room3003, HNA Tower,
8# Linhezhong Road, Tianhe District,
Guangzhou 510610
TEL : +86 (20) 3877-3819
FAX : +86 (20) 2735-3820

Hitachi Industrial Equipment Systems (Hong Kong) Co., Ltd.

8/F, Building 20E, Phase 3, Hong Kong
Science Park, Pak Shek Kok,
New Territories, Hong Kong
TEL : +852 2735-9218
FAX : +852 2735-6793

Taiwan Hitachi Asia Pacific Co., Ltd

3rd Floor, No. 167, Tun Hwa N. Road,
Hung-Kuo Building, Taipei 105, Taiwan
TEL : +886 (2) 2718-3666
FAX : +886 (2) 2514-7664

Indonesia

PT Hitachi Asia Indonesia
Menara BCA 38th Floor Suite #3804 &
3805 Jl. M. H Thamrin No.1, Jakarta
10310, Indonesia
TEL : +62 (21) 2358-6757
FAX : +62 (21) 2358-6755

Malaysia

Hitachi Industrial Equipment (Malaysia)
Sdn. Bhd.
Lot 6498, Batu 5 3/4, Lorong Haji Abdul
Manan, 42100 Klang, Selangor,
Malaysia
TEL: +60 3 3290 2323
FAX: +60 3 3290 7570

Singapore

Hitachi Asia Ltd.
(Industrial Components & Equipment
Group)
No.30, Pioneer Crescent
#10-15, West Park Bizcentral
Singapore 628560
TEL : +65-6305-7400
FAX : +65-6305-7401

Thailand

Hitachi Asia (Thailand) Co., Ltd.
18th Floor, Ramaland Bldg., No.952
Rama IV Road, Suriyawong Bangrak,
Bangkok 10500, Thailand
TEL: +66 2 632 9292
FAX: +66 2 632 9299

Viet Nam

Hitachi Asia (Viet Nam) Co., Ltd.
(Ho Chi Minh City Office)
R. 8-9-10A, 4th FL., The Landmark
Bldg, 5B Ton Duc Thang, Dist. 1, Ho
Chi Minh City, Vietnam
TEL: +84 28 3829 9725
FAX: +84 28 3829 9729

(Ha Noi Office)

23th Floor, Lotte Center Hanoi, 54 Lieu
Giai St., Cong Vi Ward, Ba Dinh Dist.,
Hanoi, Vietnam
TEL: +84 24 3933 3123
FAX: +84 24 3933 3125

Australia

Hitachi Australia Pty Ltd.
Suite 801, Level 8, 123 Epping Road
North Ryde NSW 2113, Australia
TEL: +61 2 9888 4100
FAX: +61 2 9888 4931

Europe

Germany

Hitachi Europe GmbH
Niederkasseler Lohweg 191, 40547
Düsseldorf, Germany
Tel:+49 (211) 5283 0
FAX: +49 (211) 5283 649

Latin America

Mexico

Hitachi Industrial Equipment Mexico,
S.A. de C.V.
Paseo de la Altiplanicie No.11, "Torre
Wolken" Piso 2
Col. Villas de Irapuato C.P. 36670
Irapuato, Gto, Mexico
Tel: +52 (462) 635-7251

Information in this brochure is subject to change without notice.

Hitachi Industrial Equipment Systems Co., Ltd.

For further information, please contact your nearest sales representative.



Registration number: JACO-EC99J2009
Registration date: July 22, 1996

The Energy Saving Systems Division (Taga Division) of Hitachi Industrial Equipment Systems Co., Ltd. obtained ISO 14001 certification, an international standard for environmental management systems.

Registration number: JQA-QMA 12087
Registration date: April 1, 2005

The Energy Saving Systems Division (Taga Division) of Hitachi Industrial Equipment Systems Co., Ltd. obtained international standard ISO 9001 certification for the quality assurance of the hoist motor block contained in this brochure.