

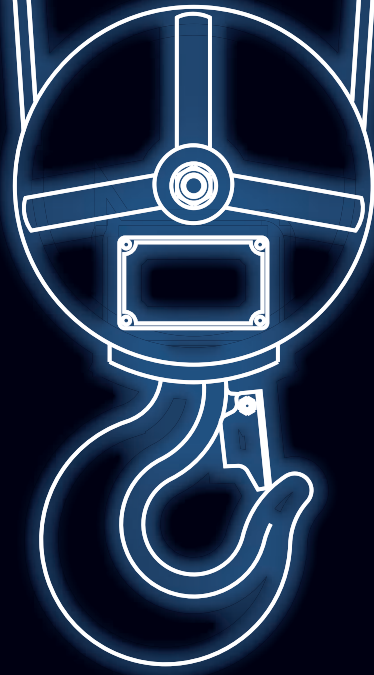

Rope Hoists

HITACHI
Inspire the Next



Hitachi Rope Hoist Catalog

Hitachi Rope Hoist

A series

V series

O thers

From 0.5 to 30 tons, Hitachi Hoists V Series Take Up All Shapes of Load.

In 1927, Hitachi developed the nation's first rope hoist. Since then, we have improved the performance of our hoists, based on the design concept of more serviceable and reliable hoists, and achieved substantial results in various industry fields.

The V Series is the culmination of what we have been targeting all these years.

We offer a wide selection of hoists, including models for special uses in addition to standard models, and hoist accessories according to your needs and applications.

We could assist you in streamlining your material handling work, saving energy and improving efficiency with our hoists.



Do not use the hoist to lift or carry humans.
Hoists are designed to carry materials only.



Hitachi Hoist Series Contents

- Introduction 2

Outline

- Features 4
- List of Hoist Types 8
- Prior to Selecting the Hoist 9

A-series

- Standard Headroom Type Hoist 10
- Low Headroom Type Hoist 12

V-series

- Standard Headroom Type Hoist 14
- Low Headroom Type Hoist 20
- Double-Rail Type Hoist 22
- Stationary Type Hoist 25
- Hoist with Creep Speed for Hoisting 28

Others

- Ultra High Lift Type Hoist 30
- Pair Hoist 34
- Special Hoisting Speed Type Hoist,
Special Traverse Speed Type Hoist 36
- Special Specifications Hoist 38
- End Carriage 39
- End Carriage with Creep Speed 42
- Wheel Unit for Toprun Type End Carriage 43
- Wheel Unit for Gantry End Carriage 44
- For Installing the Hitachi Hoist 46
- Standards and Applied Class to the Hitachi Hoists 49

Various Features Focusing on Safety and Maintainability

1 Highly Reliable Braking System Unique to Hitachi

- The hoist detects the amount of lining abrasion. The brake is equipped with an automatic adjusting device to apply brake torque in proportion to the amount of lining abrasion.
- The double braking system consists of the main brake and the auxiliary brake unit

2 Hoisting Motor with a Thermal Protector

- The hoisting motor automatically stops when sensing the heat of the motor coil in order to protect the motor from burning damage caused by heat due to overwork.

3 Efficient Maintenance is Possible

- The starting time counter in the control box facilitates checking of the lifetime of consumable parts.
- The gear inspection window in the control box allows visual checks of the condition of the gear teeth surface and lubrication to some degree.
- The punch mark on the hook indicates the reference point for the hook inspection of deformation.
- The inspection of the rope end is easy.

The Hitachi Hoist is composed of a rational system with unitized brake, motor, drum, reduction gear, and auxiliary brake.

- *Disassembly and assembly are easy.
- *Maintainability and serviceability are improved.

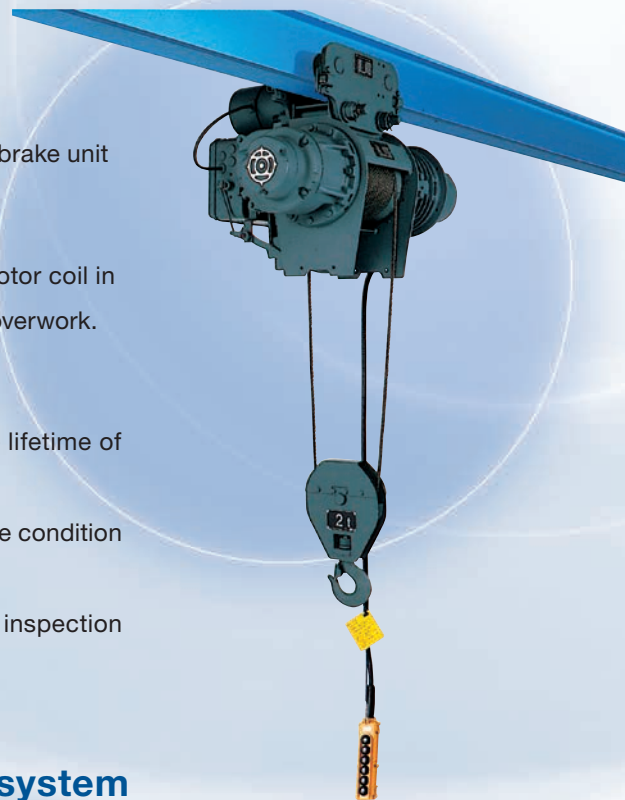

- **GEAR INSPECTION WINDOW**
Visual checks of the gear case teeth surface and lubrication conditions to some degree will improve inspection accuracy.

● REDUCTION GEAR UNIT

With a grease lubricating system, grease is filled in the gear unit on shipment, eliminating the replenishment prior to use, and prolonging the operation time. The building blocks of the spur gears (helical 1st stage) facilitate the maintenance inspection.

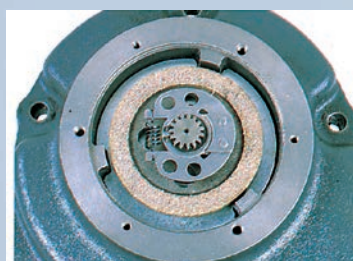

- **AUXILIARY BRAKE UNIT**
If the braking force of the main brake is reduced, the auxiliary brake unit, a new system with minimal impact, prevents the drop of the load. Together with the automatic brakes, it composes a double braking mechanism.

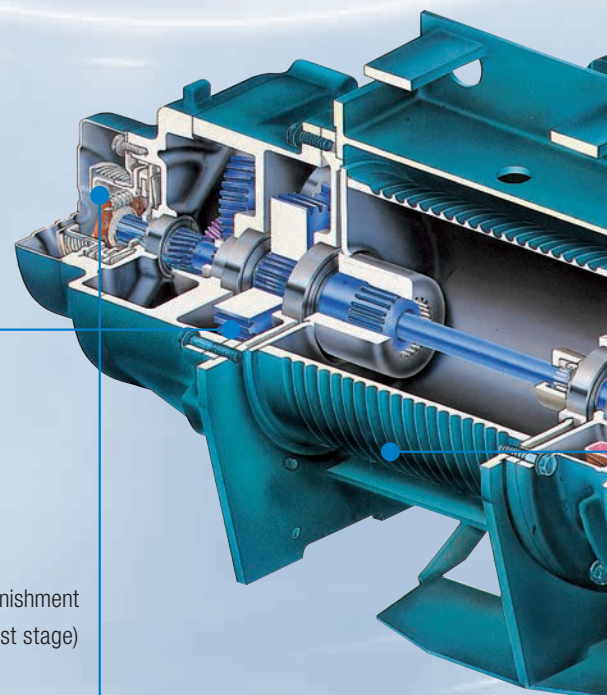

Makes Hoists More Serviceable and Reliable.

● Motor unit

Each hoist is equipped with a motor, which provides optimal starting torque for the hoist.

Employing cooling fans and large-capacity ball bearings, the class B insulating motor (class F for 7.5 and 10 tons) can withstand severe operating conditions. The hoisting motor is provided with a thermal protector, which senses the heat of the motor coil and functions to protect the motor from burning damage caused by over-frequent starting times.

■ CONTROL BOX

● Starting time counter

The cumulative number of starting times is indicated on this counter. Because the total number of times the parts have been operated is known on this counter, it is useful for planning the maintenance and procurement of consumable parts such as brakes, electromagnetic switches, and wire ropes.

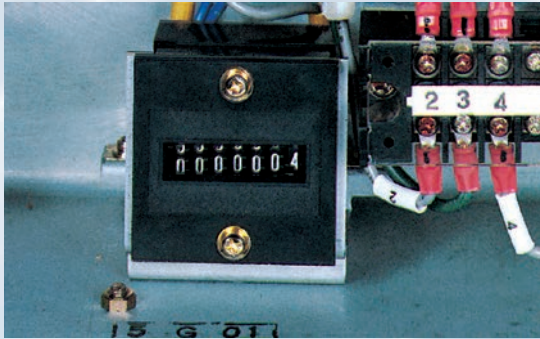

● Electromagnetic switch with mechanical interlock

A mechanical interlock is provided for the electromagnetic switch to prevent malfunction.

● Double-limit switch

When the load block has reached the upper limit, the control circuit of the electromagnetic switch is turned off and the operation is stopped. Should a short-circuit occur, or the main circuit continue to operate due to a reverse phase connection, causing the load block to move further upward, the motor main circuit is cut off.

● Clamp type cover

The clamp type control box cover facilitates opening and closing.

● Brake unit

The brake is equipped with an automatic adjusting device, which automatically adjusts brake torque in proportion to the amount of lining abrasion. Conventional adjustments of the brake will not be required.

■ STEEL DRUM and SHEAVE

The drums (2- and 4-fall models for 2 to 5 tons, except for ultra high lift hoists) and sheaves (except for 7.5 and 10 tons) are made of steel plate, and the grooves are processed by a special press method. This makes the life of the drums and sheaves about three times longer than existing cast metal ones (compared with our products).

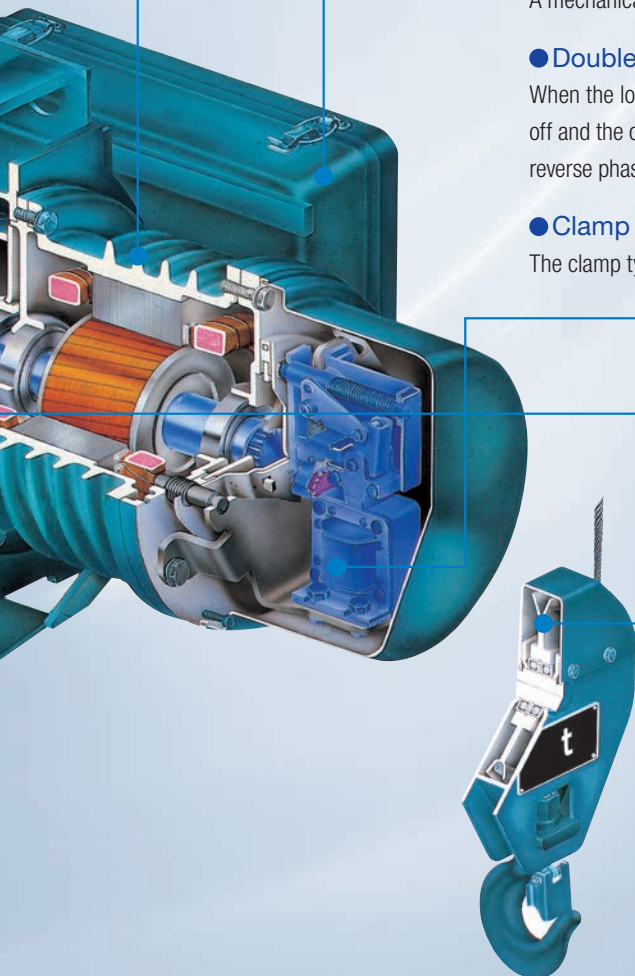
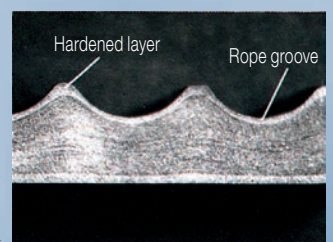

● Reduction in size and weight

The K size, from the road surface of the traverse rail to the top surface of the double rail hoist, is reduced by 20% and weight is reduced by 10% (compared with our conventional products). This downsizing improves installation and operability.

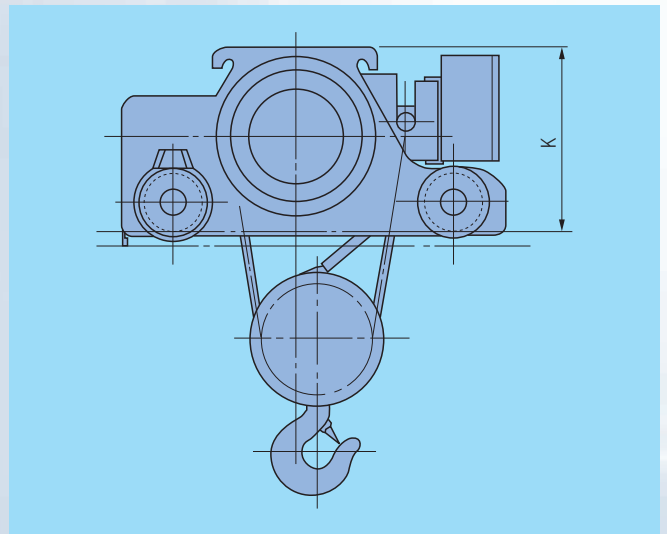

■ Thick Wire Rope

The wire rope provided with a sufficient margin features a long life.

● Rope end

Inspection of the rope end has become much easier.



■ Hook

● Punch mark

The punch mark on the hook indicates the reference point for easy inspection of deformation.



● Load block fitted with a safety lever

The load block is provided with a safety lever to prevent the rope from dislodging in addition to a safety cover.

● Integrated pushbutton cable

The pushbutton cable unique to Hitachi integrates the cable and protective wire into a single assembly to improve durability and operability.

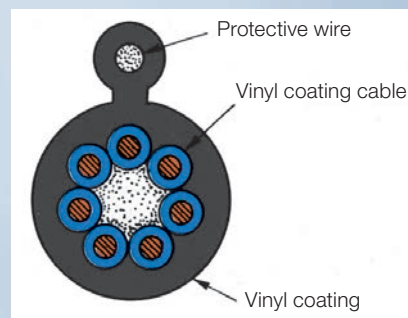

● User-friendly pushbutton

The plastic push button is of a totally enclosed type.

Motorized trolley

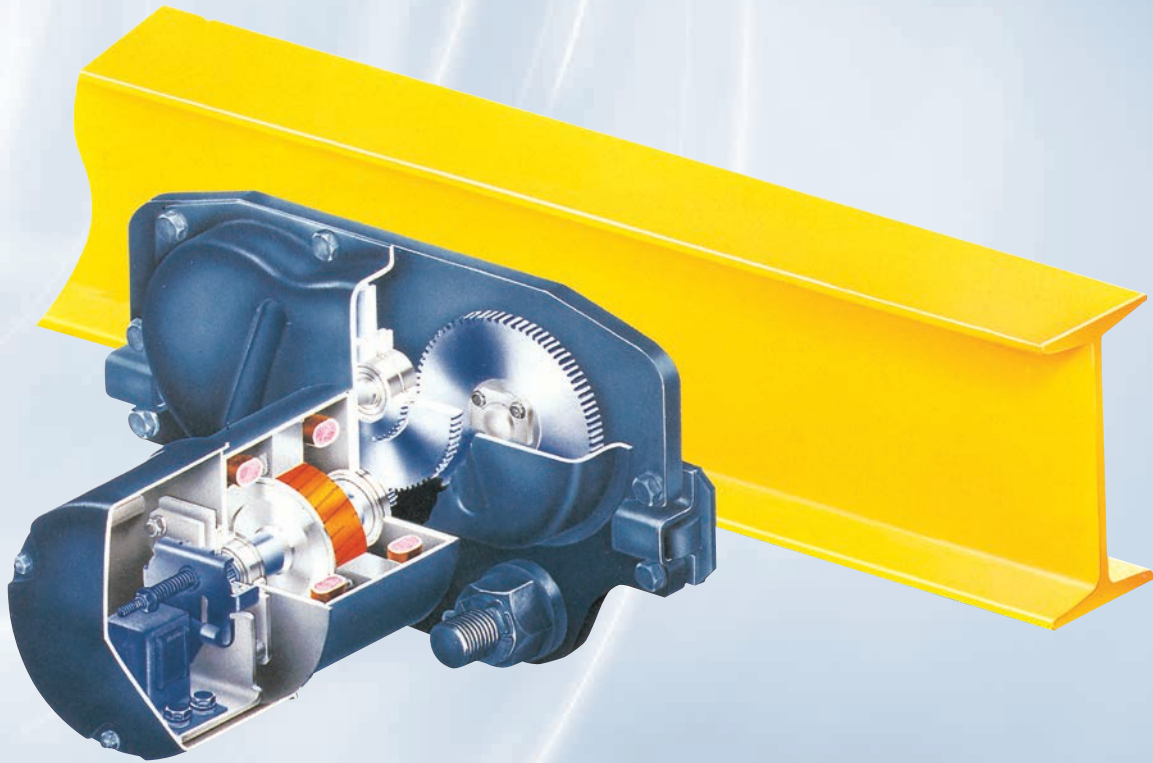

● Long life wheel

The hoist traverses by guide rollers and the flangeless wheels remarkably reduce the wear of the I-beam and wheels. The built-in brake facilitates positioning. The brake torque is adjustable.

Besides the standard and low headroom types, wheels of the double rail type (2 to 5 tons) are quenched, prolonging the lifetime more than 2.5 times that of conventional hoists (compared with our products).

● Self-adjusting center core (Double rail hoist)

Using a trolley with a self-adjusting center core, the wheels can closely follow the rails.

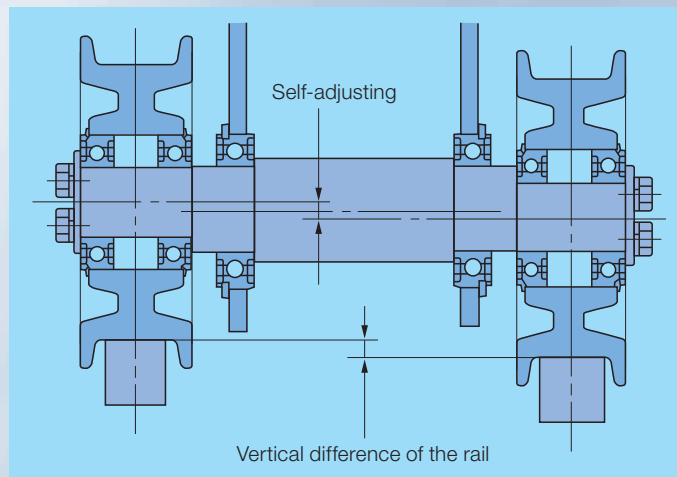
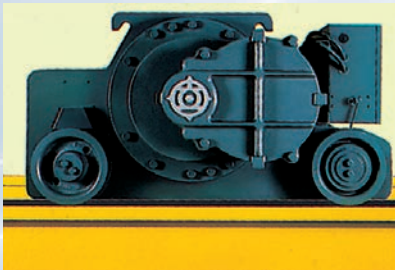

Optimum model Selectable from a Great Variety of Types

A-series		V-series		
Standard Headroom	Low Headroom	Standard Headroom	Low Headroom	Double-Rail
		1/2t 6m,12m	1/2t 6m	
1t 6m,12m	1t 6m	1t 6m,12m	1t 6m,12m	
2t 6m,12m	2t 6m	2t 6m,12m	2t 6m,12m	2t 12m
3t 6m,12m	3t 6m	3t 6m,12m	3t 6m,12m	3t 6m,12m
		5t 8m,12m	5t 6m	5t 8m,12m
		7.5t 8m,12m		7.5t 8m,12m
		10t 8m,12m		10t 8m,12m
		15t 8m,12m		15t 8m,12m
		20t 12m		20t 12m
				30t 12m

Specially designed hoists

- Stationary
- Hoist with creep speed for hoisting
- Ultra high lift type hoist
- Pair hoist
- Special hoisting speed type hoist
- Special traversing speed type hoist
- Explosionproof type hoist based on JIS
- Multi hook type hoist
- Hoist with upper / lower limit switches
- Hoist with load limiter

Prior to Selecting Hoist

Explanation of Hitachi hoist types for hoist with trolley

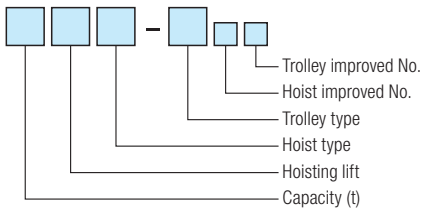

For hoist only

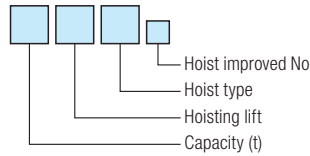

Capacity	Hoisting lift		Hoist type	Trolley type
	Low lift	High lift		
Rated load indicated by tons	No mark	H	V-series Standard headroom type.....M Low headroom type.....L Double rail type.....D A-series Standard headroom type.....AM Low headroom type.....AL	Manual driven trolley.....P Chain driven trolley.....C Motorized trolley.....T

* Serial numbers are applied to improved No.

Example

V-series, 2t, high-lift, standard headroom type hoist with motorized trolley



Standard specifications

Specifications

- Control Voltage
200V for V-series, 24V for A-series
- Operating method
Push-button operation using a control panel on the floor
- Rating
30 minutes (to JIS C9620, Japanese Industrial Standard)

Standard push-buttons

Type	No. of push buttons	Indication
Without Motorized Trolley	2	↑ ↓
With Motorized Trolley Except 5t Double Rail Type (up to 5t)	6	↑ ↓ ← → ↻ ↻
With Motorized Trolley Include 5t Double Rail Type (7.5t and up)	8	ON OFF ↑ ↓ ← → ↻ ↻

Power feed system

Type	Power feed system
Suspension-type with chain-driven trolley	Cable
With motorized trolley	Cable

* No cable is provided in the cable power feed system.

Series Selection

When selecting an electric chain hoist, the operating environment, operating time, and operating frequency must be taken into consideration.

Operating time and load ratio

Use within the range of section.

Load Condition	Load Ratio	Mean operating hour per day (h)					
		~1	~2	~4	~8	~16	16~
Light	$K \leq 0.5$	V-series 40% ED (40%ED)					
Medium	$0.5 < K \leq 0.63$	400 Stars/h (250 Stars/h)					
Heavy	$0.63 < K \leq 0.8$	A-series 25% ED					
Severe	$0.8 < K$	250 Stars/h					

Load condition

Light : This is normally used at a load of 1/2 the rated load, and on rare occasions at the rated load.
 Medium : This is normally used at a load of 1/2 to 2/3 the rated load, and occasionally at the rated load.
 Heavy : This is normally used at loads above 2/3 the rated load, and often at the rated load.
 Severe : This is mostly used at the rated load or close to this load.

- * If use is expected to exceed the above range, then an electric chain hoist with a higher capacity must be selected, so please consult with HITACHI.
- ** Rating in parenthesis is for 15t and above.

Operating environment

- Use in locations with an ambient temperature of -10°C to 40°C (with no freezing) and humidity of 90% or less (no condensation).

Protective construction IP44

Applicable standards

Crane construction standards

- The main body and the trolley for a hoist with a chain-driven trolley are delivered separately.

n : Inching count (times) per lifting or lowering operation.	t ₁ , t ₂ , t ₃ : Ratio of the operating time of each load to the total operating time
N : Transport count (times) within 1 hour	P ₁ , P ₂ , P ₃ : Each load ratio (ratio of the load to each rated load)
ℓ : Lift(m)	
V : Hoisting speed(m/min)	

In addition to the general specifications, (1) starting frequency, (2) duty factor, and (3) load ratio must be taken into consideration.

Calculation method

(If the calculated value exceeds the standard specification, then it is a dedicated specification.)

(1) Max. starting frequency α (Starts/h)=2×n×N

Example calculation

The starting frequency is the cumulative sum of the inching operation count, so this must be calculated by estimating the number of inchings per hoist round trip.

$$2 \times 3 \times 25 = 150 \text{ Starts/h}$$

Lifting+Lowering (Number of times) No. of transfer per hour (times) Inching count (times) per lifting or lowering operation.

(2) Duty factor β(%)= $\frac{\text{The total motor ON time (minutes) per hour under the most frequent condition.}}{60 \text{ min}} \times 100$

$$= 2 \times \frac{\ell}{V} \times N \times \frac{1}{60 \text{ min}} \times 100$$

Example calculation

Lift(m) No. of transfer per hour(Times)

$$2 \times \frac{3}{10} \times 25 \div 60 \times 100 = 25\%$$

Lifting+Lowering (Times) 1 hour (60 min) Hoisting speed (m/min)

(3) Load ratio K= $\sqrt[3]{P_1^3 t_1 + P_2^3 t_2 + P_3^3 t_3 + \dots}$

Example calculation

When a 0.4t load is suspended on a 1-ton rated load rope hoist for a one-way trip, with a no-load return trip. (The lifting sling is 0.3t).

$$K = \sqrt[3]{(0.3+0.4)^3 \times 0.5 + 0.3^3 \times 0.5} \approx 0.57$$

In this case, the load condition is comparable to "medium" and the average operating time per day is 8 hours or less. If used for a longer time than this, an electric chain hoist with a higher capacity must be selected.

A-series HOIST with Motorized Trolley

Standard Headroom Type Hoist

(With suspension/chain-driven and motorized trolley)

This is an orthodox type of hoist widely utilized for general purposes. It boasts high performance for use in rugged jobs such as general production in factories, mining, railroads, and warehouses.

Standard - Headroom Type Hoist

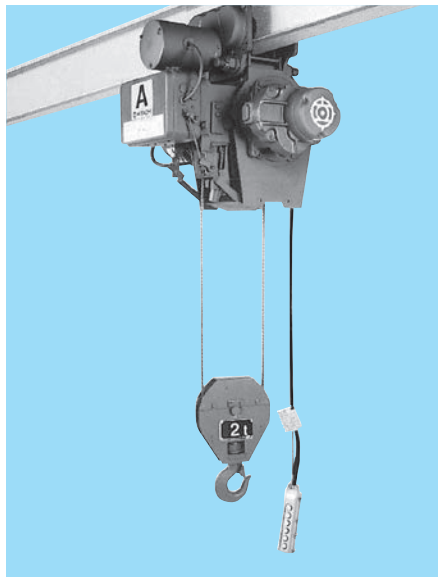

Specifications

Capacity (t)		1	2	3	
Hoisting lift (m)		6 and 12			
Hoisting	Speed (m/min)	50Hz	7	6	5
		60Hz	8.4	7	6
	Motor (kW)	50Hz	1.2	2.1	2.6
		60Hz	1.5	2.4	3.1
No. of poles		4			
Traversing	Speed (m/min)	50Hz	21		
		60Hz	25		
	Motor (kW)	50Hz	0.30	0.30	0.45
		60Hz	0.36	0.36	0.55
No. of poles		4			
Wire rope	No. of falls		2		
	Composition		6×Fi (29)-B		
	Diam. (mm)		φ 8	φ 11.2	φ 14
Rating		25% ED 250 Starts/h			
Operating method		Floor-controlled Pushbutton operation			
Electric source (3 phase)		200V 50/60Hz, 220V 60Hz, 380-400V 50Hz, 415V 50Hz, 440-460V 60Hz			
Control voltage (V)		24 — 27			

Dimensions

Suspension Type Hoist

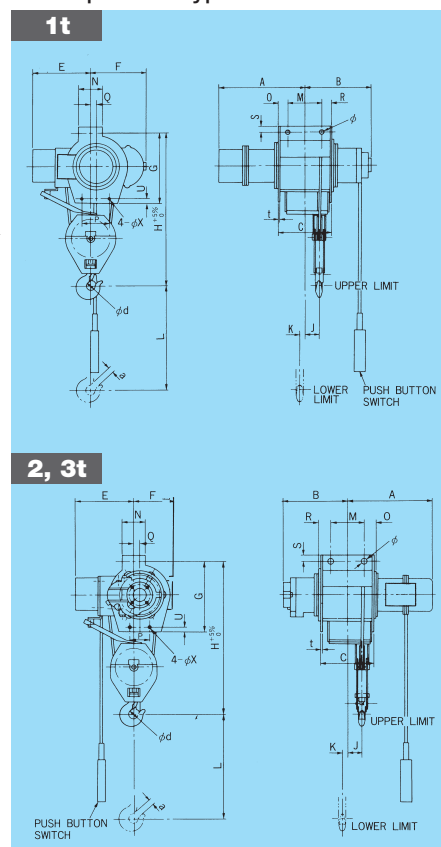



Table of Dimensions

Model	1AM ₆	1HAM ₆	2AM ₇	2HAM ₇	3AM ₆	3HAM ₆	
Capacity (t)	1		2		3		
Approx. dimensions (mm)	L	6,000	12,000	6,000	12,000	6,000	12,000
	H	710		910		1,050	
	A	480	650	545	580	565	605
	B	350	385	435	615	460	640
	M	200		200		200	
	φ	26		36		36	
	N	139		139		164	
	E	345		400		460	
	F	255		220		245	
	φ d	45		56		71	
	a	23		36		42	
	J	85	115	75	100	80	110
	K	20	90	30	110	35	120
	O	47	217	56	91	65	106
	R	47	80	58	237	79	262
	Q	32.5		35.5		41.5	
	S	35	40	35		35	
	C	294	497	314	528	344	568
	t	9		9		9	
	G	390		500		555	
P	120		120		180		
U	28		28		35		
φ X	10		10		14		
Approx. weight (kg)	115	125	190	210	230	255	
Push-button indication			 				

Standard Headroom Type Hoist

Dimensions Standard-Headroom Type with Motorized Trolley

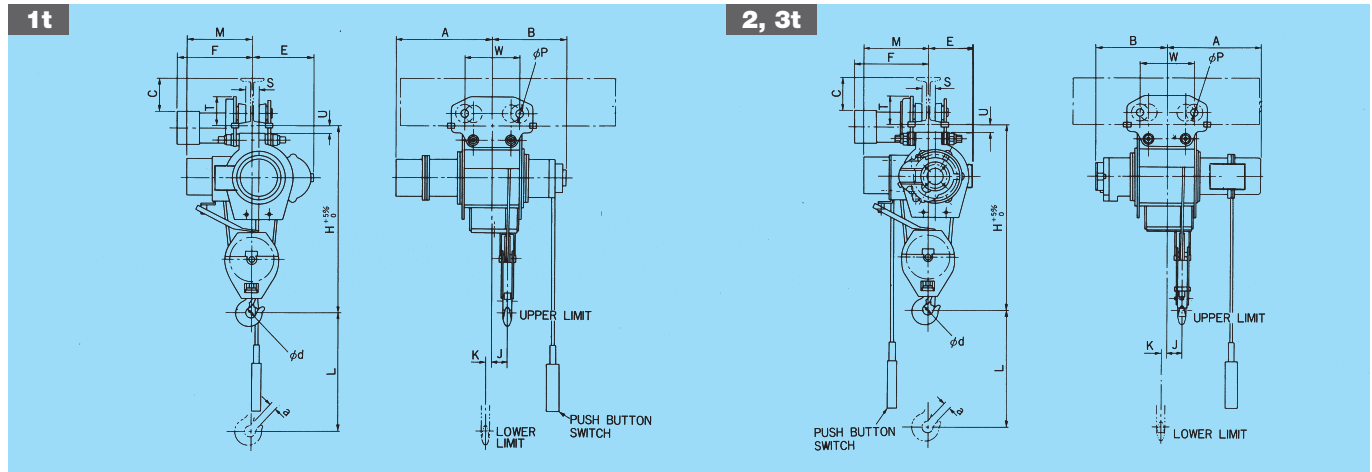

Table of Dimensions

Model	1AM-T _{6S}		1HAM-T _{6S}		2AM-T _{7S}		2HAM-T _{7S}		3AM-T _{6S}		3HAM-T _{6S}					
Hoist type	1AM ₆		1HAM ₆		2AM ₇		2HAM ₇		3AM ₆		3HAM ₆					
Trolley type	1T _S		1T _S		2T _S		2T _S		3T _S		3T _S					
Capacity (t)	1				2				3							
Approx. dimensions (mm)	L	6,000		12,000		6,000		12,000		6,000		12,000				
	H	790				985				1,115						
	A	480		650		545		580		565		605				
	B	350		385		435		615		460		640				
	M	345				400				460						
	W	200/290				200/290				230/310						
	K	20		90		30		110		35		120				
	J	85		115		75		100		80		110				
	E	255				220				245						
	ϕ d	45				56				71						
ϕ p	96				96				128							
a	23				36				42							
Min. curve Radius (m)	1.5				1.8				2.0							
Dimensions (mm)																
I- Beam	F	S	T	U	C	F	S	T	U	C	F	S	T	U	C	
200×100×7	374	42	148	47 (42)	135	378	42	148	42	135						
250×125×7.5	387	67	151	44 (39)	185	391	67	151	39	185	417	52	177	38	180	
300×150×11.5	400	92	160	35 (30)	225	404	92	160	30	225	430	77	187	28	220	
450×175×11											443	102	185	30	370	
Approx. weight (kg)	165		175		255		275		320		345					
Push-button indication																

NOTES : 1. Dimensions W are for the drive side/driven side.
 2. Unless otherwise specified trolley is being assembled so as to meet smudged I-beam size.
 3. () dimensions represent dimensions of 1HAM₆ (Hoist type)

Low Headroom Type Hoist

Low-Headroom Type Hoist

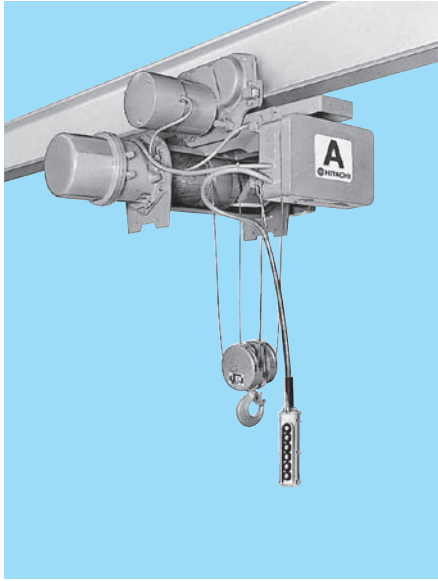

Specifications

Capacity (t)			1	2	3
Hoisting lift (m)			6		
Hoisting	Speed (m/min)	50Hz	7	6	5
		60Hz	8.4	7	6
	Motor (kW)	50Hz	1.2	2.1	2.6
		60Hz	1.5	2.4	3.1
No. of poles		4			
Traversing	Speed (m/min)	50Hz	21		
		60Hz	25		
	Motor (kW)	50Hz	0.30	0.30	0.45
		60Hz	0.36	0.36	0.55
No. of poles		4			
Wire rope	No. of falls		4		
	Composition		6×W (19)-B	6×Fi (29)-B	
	Diam. (mm)		φ 6.3	φ 8	φ 10
Rating			25% ED 250 Starts/h		
Operating method			Floor-controlled Pushbutton operation		
Electric source (3 phase)			200V 50/60Hz, 220V 60Hz, 380-400V 50Hz, 415V 50Hz, 440-460V 60Hz		
Control voltage (V)			24 — 27		

Low Headroom Type Hoist

Dimensions

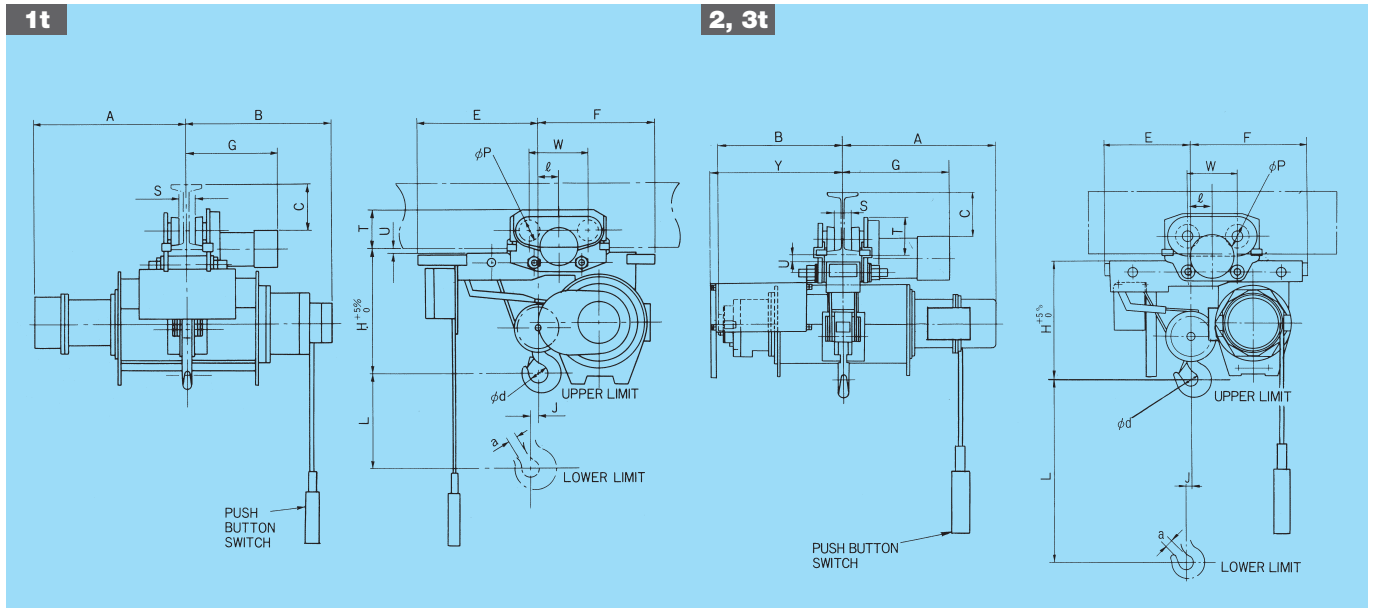

Table of Dimensions

Model		1AL-T ₅₅					2AL-T ₅₅					3AL-T ₅₅				
Hoist type		1AL _s					2AL _s					3AL _s				
Trolley type		1T _s					2T _s					3T _s				
Capacity (t)		1					2					3				
Approx. dimensions (mm)	L	6,000					6,000					6,000				
	H	425					515					600				
	A	600					655					705				
	B	475					545					585				
	W	200/290					200/290					230/310				
	E	420					365					400				
	F	375					480					575				
	ϕ d	45					56					71				
	J	28					42					46				
	Y	—					625					620				
	ϕ p	96					96					128				
a	23					36					42					
∅	55					85					100					
Min. curve Radius (m)		1.5					1.8					2.0				
I- Beam		Dimensions (mm)														
		S	T	U	C	G	S	T	U	C	G	S	T	U	C	G
200×100×7		42	148	52	135	374	42	150	32	135	378					
250×125×7.5		67	151	49	185	387	67	153	29	185	391	52	177	28	180	417
300×150×11.5		92	160	40	225	400	92	163	19	225	404	77	187	18	220	430
450×175×11												102	185	20	370	443
Approx. weight (kg)		180					270					370				
Push-button indication																

NOTE : Dimensions W are for the drive side/driven side.
 Unless otherwise specified trolley is being assembled so as to meet smudged I-beam size.

V-series HOIST with Motorized Trolley

Standard Headroom Type Hoist

(With suspension/chain-driven and motorized trolley)

This is an orthodox type of hoist widely utilized for general purposes. It boasts high performance for use in rugged jobs such as general production in factories, mining, railroads, and warehouses.

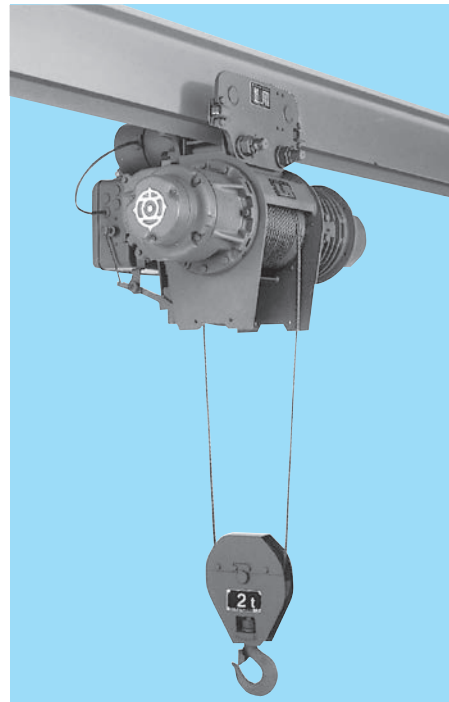

Specifications

Capacity (t)		1/2	1	2	3	5	7.5	10	15	20	
Hoisting lift (m)		6 and 12				8 and 12				12	
Hoisting	Speed (m/min)	50Hz	11	11	8.4	7.5	6.7	6.0	5.0	5.0	4.2
		60Hz	13	13	10	9	8	7.2	6.0	6.0	5.0
	Motor (kW)	50Hz	1.0	1.9	2.9	4.2	5.9	7.9	8.8	6.7×2	7.5×2
		60Hz	1.2	2.3	3.5	5	7	9.5	10.5	8×2	9×2
No. of poles		4				4					
Traversing	Speed (m/min)	50Hz	21				14				
		60Hz	25				17				
	Motor (kW)	50Hz	0.30	0.30	0.30	0.45	0.63	0.47×2	0.47×2	0.7×2	0.7×2
		60Hz	0.36	0.36	0.36	0.55	0.75	0.56×2	0.56×2	0.84×2	0.84×2
No. of poles		4				6		4			
Wire rope	No. of falls		2			4					
	Composition		6×W(19)-B		6×Fi(29)-B					6×Fi(29)IWRC-B	
	Diam.(mm)		φ 6.3	φ 8	φ 11.2	φ 14	φ 12.5	φ 14	φ 16	φ 20	φ 22.4
Rating		40%ED400 Starts/h						40%ED250 Starts/h			
Operating method		Push-button operation					Push-button operation				
Electric source (3 phase)		200V 50/60Hz, 220V 60Hz, 380-400V 50Hz, 415V 50Hz, 440-460V 60Hz									
Control voltage		200V 50/60Hz									

Hoist with Motorized Trolley

Here's Convenience

This hoist proves handy for use in a busy factory where the load traveling range is wide and transporting operations are frequent. The motorized trolley efficiently transports loads to destined locations. When the rail is installed the full length or width of a building's ceiling, the hoist may be used as an overhead traveling crane. Loads can be speedily transported merely by manipulating the push-button switches. Several hoist units can be mounted on one rail.

Dimensions

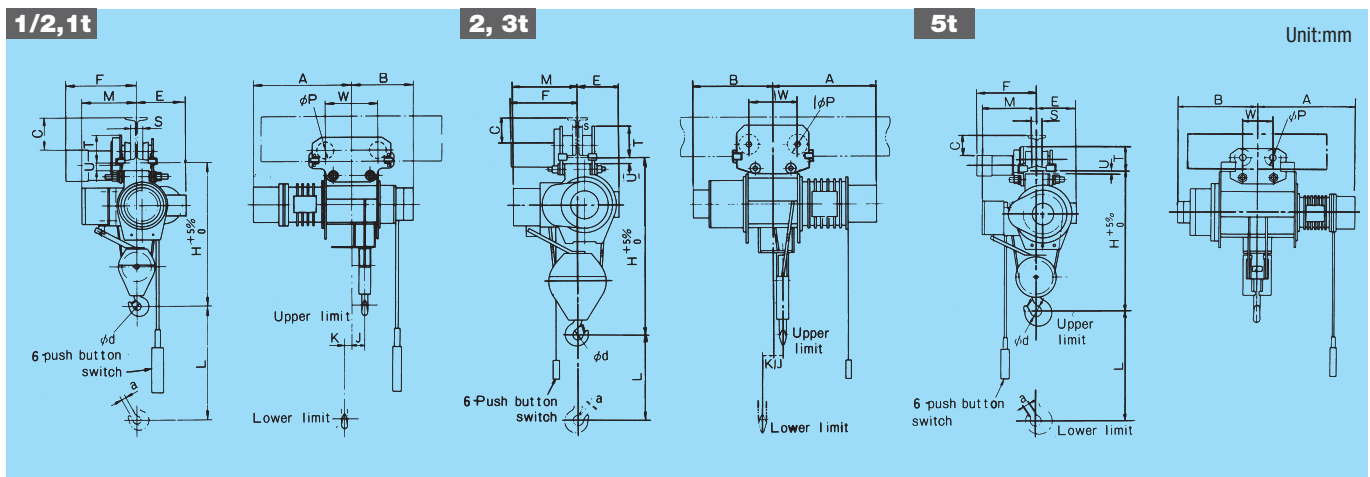

Table of Dimensions

Model	1/2M-T65		1/2HM-T65		1M-T65		1HM-T65		2M-T75		2HM-T75		3M-T65		3HM-T65		5M-T55		5HM-T55											
Hoist type	1/2M6		1/2HM6		1M6		1HM6		2M7		2HM7		3M6		3HM6		5M5		5HM5											
Trolley type	1/2T5		1/2T5		1T5		1T5		2T5		2T5		3T5		3T5		5T5		5T5											
Capacity (t)	1/2				1				2				3				5													
Approx. dimensions (mm)	L	6,000	12,000	6,000	12,000	6,000	12,000	6,000	12,000	6,000	12,000	6,000	12,000	6,000	12,000	8,000	12,000	8,000	12,000	8,000	12,000									
	H	740		790		985		1,115		1,190																				
	A	485	655	545	715	595	630	645	690	845	955																			
	B	355	380	350	385	435	615	475	660	690	800																			
	M	335		345		415		460		455																				
	W	200/290		200/290		200/290		230/310		250/330																				
	K	20	100	20	90	30	110	35	120	-	-																			
	J	80	105	85	115	75	100	80	110	-	-																			
	φ d	40		45		56		71		90																				
	φ p	96		96		96		128		156/140(DRIVE SIDE/DRIVEN SIDE)																				
a	21		23		36		42		58																					
Min. curve radius (m)	1.3(5.0)				1.5				1.8				2.0				3.0													
Dimensions with respect to I-beam	E	F	S	T	U	C	E	F	S	T	U	C	E	F	S	T	U	C	E	F	S	T	U	C	E	F	S	T	U	C
(150×75×5.5)	190	361	17	147	53(43)	85																								
200×100×7	190	374	42	148	52(42)	135	255	374	42	148	47(42)	135	220	378	42	148	42	135												
250×125×7.5	190	387	67	151	49(39)	185	255	387	67	151	44(39)	185	220	391	67	151	39	185	245	417	52	177	38	180						
300×150×11.5							255	400	92	160	35(30)	225	220	404	92	160	30	225	245	430	77	187	28	220	305	450	77	225	30	215
450×175×11																			245	443	102	185	30	370	305	463	102	223	32	365
Approx. weight (kg)	145		155		175		195		280		310		385		415		685		745											

- NOTES : 1. Dimensions W represent dimensions of drive side/driven side.
 2. 1/2 ton-When an I-beam (150×75×5.5) is used, the minimum curve radius is 5m.
 3. 1/2 ton-When an I-beam (150×75×5.5) is used, 50mm-thick shims are necessary between the building and the I-beam.
 4. Unless otherwise specified trolley is being assembled so as to meet smudged I-beam size.
 5. () dimensions represent dimensions of 1/2HM6 and 1HM6 (Hoist type)

Outline

A-series

V-series

Others

Hoist with Motorized Trolley

Dimensions

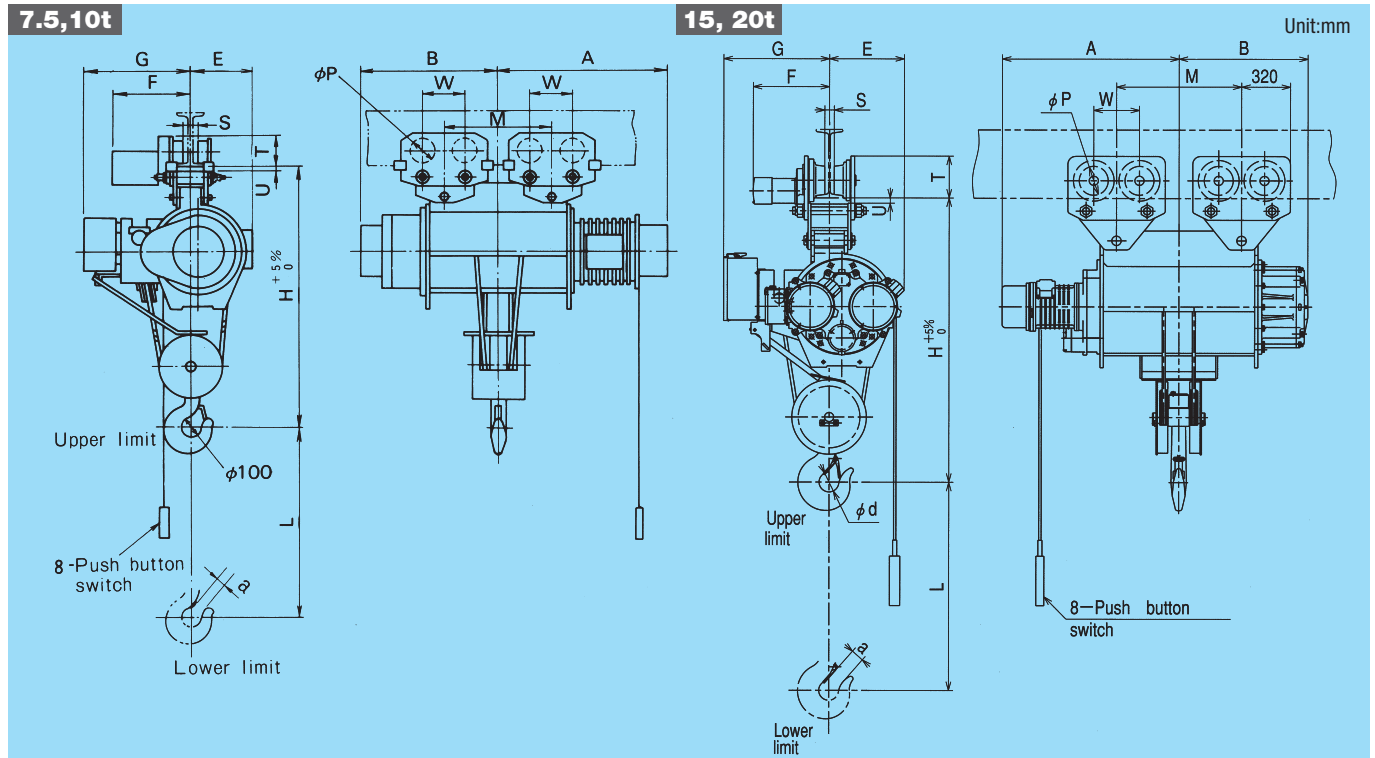

Table of Dimensions

Model	7.5M-T ₅₅		7.5HM-T ₅₅		10M-T ₅₅		10HM-T ₅₅		15M-T ₅₅		15HM-T ₅₅		20HM-T ₅₅				
Hoist type	7.5M ₅		7.5HM ₅		10M ₅		10HM ₅		15M ₅		15HM ₅		20HM ₅				
Trolley type	4FT ₅ ×2		4FT ₅ ×2		5FT ₅ ×2		5FT ₅ ×2		10AT ₅ ×2		10AT ₅ ×2		10AT ₅ ×2				
Capacity (t)	7.5				10				15				20				
Approx. dimensions (mm)	L	8,000		12,000		8,000		12,000		8,000		12,000		12,000			
	H	1,345				1,515				1,865				2,010			
	A	1,075		1,150		1,075		1,150		1,060		1,160		1,210			
	B	830		905		885		960		750		850		900			
	E	315				355				500				500			
	G	570				590				705				705			
	M	560		760		650		786		820		900		900			
	W	230/310(Drive side/Driven side)				230/330(Drive side/Driven side)				300				300			
	φ d	100				100				130				165			
	φ p	128				156/140(Drive side/Driven side)				190				190			
a	69				69				86				108				
Min. curve Radius (m)	Straight				Straight				Straight				Straight				
Dimensions with respect to I-beam	S	T	U	F	S	T	U	F	S	T	U	F	S	T	U	F	
450×175×11	102	184	30	453	102	225	30	460	62	280	30	524	62	280	30	524	
600×190×13	117	189	25	461	117	230	25	468	77	285	25	532	77	285	25	532	
Approx. weight (kg)	930		990		1,230		1,290		2,340		2,540		2,940		2,940		

NOTE : Unless otherwise specified trolley is being assembled so as to meet smudged I-beam size.

Lug Suspension Type Hoist

Here's Convenience...

This hoist is handy when hoisting or lowering cargo in a definite location. Transportation of the hoist main body, installation to the ceiling, and hoist removing are quite simple.

Dimensions

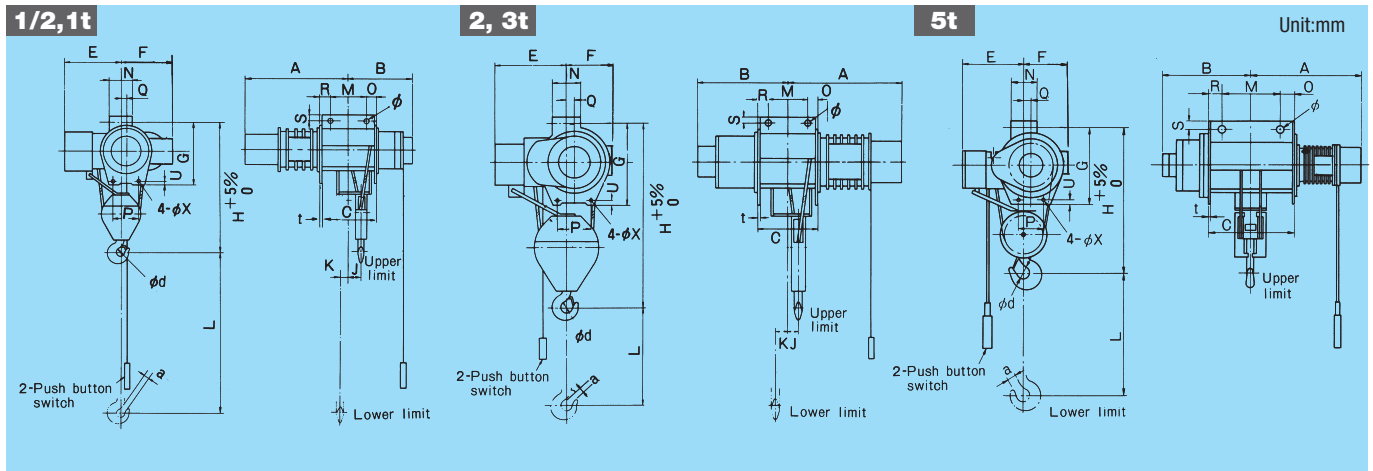
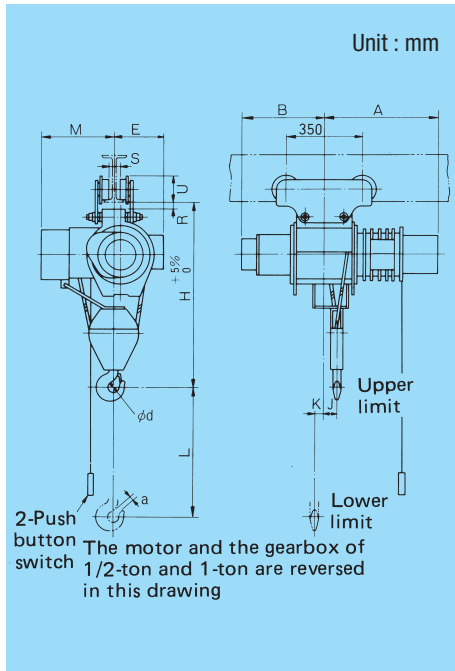

Table of Dimensions

Model	1/2M ₆	1/2HM ₆	1M ₆	1HM ₆	2M ₇	2HM ₇	3M ₆	3HM ₆	5M ₅	5HM ₅	
Capacity (t)	1/2		1		2		3		5		
Approx. dimensions (mm)	L	6,000	12,000	6,000	12,000	6,000	12,000	6,000	12,000	8,000	12,000
	H	660		710		910		1,050		1,110	
	A	485	655	545	715	595	630	645	690	845	955
	B	355	380	350	385	435	615	475	660	690	800
	M	200		200		200		200		270	
	φ	26		26		36		36		46	
	N	114		139		139		164		189	
	E	335		345		415		460		455	
	F	190		255		220		245		305	
	φ d	40		45		56		71		90	
	a	21		23		36		42		58	
	J	80	105	85	115	75	100	80	110	—	—
	K	20	100	20	90	30	110	35	120	—	—
	O	52	80	47	80	56	91	65	106	198	310
	R	52	230	47	217	58	237	79	262	198	310
	Q	25.5		32.5		35.5		41.5		52.5	
	S	30	40	35	40	35		35		50	
	C	304	510	294	497	314	528	344	568	666	890
	t	9		9		9		9		12	
G	380		390		500		555		590		
P	120		120		120		180		180		
U	28		28		28		35		35		
φ X	10		10		10		14		14		
Approx. weight (kg)	95	105	125	145	215	245	295	325	550	610	

Hoist with Push-Driven Trolley

■ Dimensions



■ Table of Dimensions

Model	½M-P ₆₅	½HM-P ₆₅	1M-P ₆₅	1HM-P ₆₅	2M-P ₇₅	2HM-P ₇₅	3M-P ₆₅	3HM-P ₆₅	
Hoist type	½M ₆	½HM ₆	1M ₆	1HM ₆	2M ₇	2HM ₇	3M ₆	3HM ₆	
Trolley type	1P ₅	1P ₅	1P ₅	1P ₅	3P ₅	3P ₅	3P ₅	3P ₅	
Capacity (t)	½		1		2		3		
Approx. dimensions (mm)	L	6,000	12,000	6,000	12,000	6,000	12,000	6,000	12,000
	H	730		775		985		1,115	
	A	485	655	545	715	595	630	645	690
	B	355	380	350	385	435	615	475	660
	M	335		345		415		460	
	E	190		255		220		245	
	K	20	100	20	90	30	110	35	120
	J	80	105	85	115	75	100	80	110
	φd	40		45		56		71	
	a	21		23		36		42	
Min. curve radius (m)	4.0		4.0		4.0		4.0		
Dimensions with respect to I-beam	U	R	S	U	R	S	U	R	S
150×75×5.5	38 (28)	115	26						
200×100×7	37 (27)	116	51	32 (27)	116	51	40	140	33
250×125×7.5	34 (24)	118	76	29 (24)	118	76	37	143	58
300×150×11.5				19 (14)	128	101	27	153	83
450×175×11								29	151
Approx. weight (kg)	120	130	150	170	265	295	345	375	

NOTES : 1. Unless otherwise specified trolley is being assembled so as to meet smudged I-beam size.
2. () dimensions represent dimensions of ½HM₆ and 1HM₆ (Hoist type)

■ Dimensions

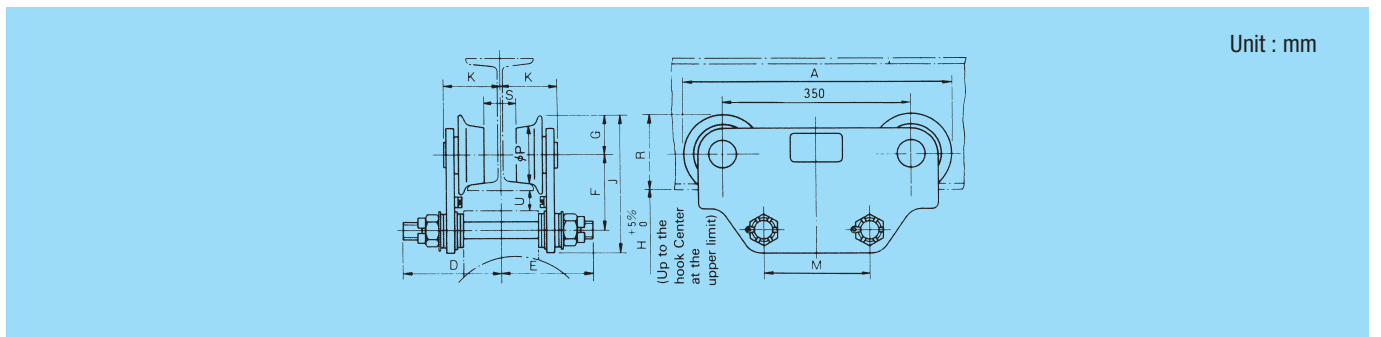

■ Table of Dimensions

Model	1P ₅						3P ₅											
Capacity (t)	½			1			2			3								
Approx. dimensions (mm)	A	476						500										
	F	120						140										
	G	63						75										
	H	730			775			985			1,115							
	J	223						257										
	M	200						200										
φp	85						110											
Min. curve radius (m)	4.0						4.0											
Dimensions with respect to I-beam	D	E	K	U	R	S	D	E	K	U	R	S	D	E	K	U	R	S
(150×75×5.5)	178	149	79	38 (28)	115	26												
200×100×7	178	149	92	37 (27)	116	51	178	149	92	32 (27)	116	51	198	198	93	40	140	33
250×125×7.5	178	149	105	34 (24)	118	76	178	149	105	29 (24)	118	76	198	198	106	37	143	58
300×150×11.5							178	149	118	19 (14)	128	101	198	198	119	27	153	83
450×175×11													198	198	132	29	151	108
Approx. weight (kg)	25						50											
Applicable hoist type	½(H)M ₆			1(H)M ₆			2(H)M ₇			3(H)M ₆								

NOTES : 1. Weight indicates empty weight of trolley.
2. This trolley is only for standard headroom type hoist.
3. I-beam (150×75×5.5) is only for ½-ton hoist.
4. () dimensions represent dimensions of ½HM₆ and 1HM₆ (Hoist type)
5. Unless otherwise specified trolley is being assembled so as to meet smudged I-beam size.

Hoist with Chain-Driven Trolley

Dimensions

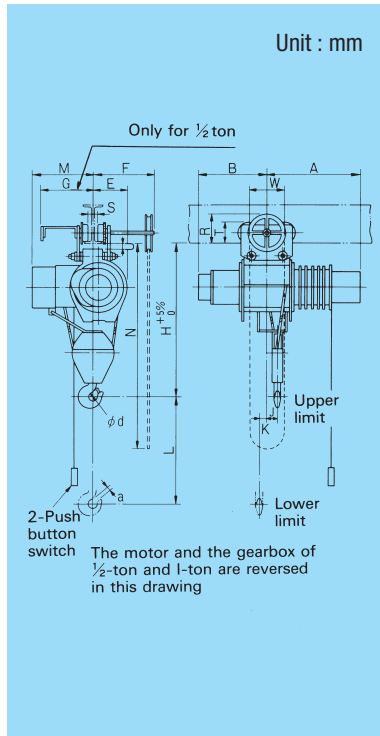

Table of Dimensions

Model	1/2M-C65		1/2HM-C65		1M-C65		1HM-C65		2M-C75		2HM-C75		3M-C65		3HM-C65																	
Hoist type	1/2M6		1/2HM6		1M6		1HM6		2M7		2HM7		3M6		3HM6																	
Trolley type	1/2C5				1C5				2C5				3C5																			
Capacity (t)	1/2				1				2				3																			
Approx. dimensions (mm)	L	6,000	12,000	6,000	12,000	6,000	12,000	6,000	12,000	6,000	12,000	6,000	12,000	6,000	12,000	6,000	12,000															
	H	715				775				985				1,115																		
	A	485	655	545	715	595	630	645	690																							
	B	355	380	350	385	435	615	475	660																							
	M	335				345				415				460																		
	E	190				255				220				245																		
	W	189/240				189/350				231/350				231/350																		
	K	20	100	20	90	30	110	35	120																							
	J	80	105	85	115	75	100	80	110																							
	φd	40				45				56				71																		
	a	21				23				36				42																		
	N	6,300	12,800	6,300	12,800	6,200	12,700	6,200	12,700																							
Min. curve radius (m)	1.3				4.0				4.0				4.0																			
Dimensions with respect to I-beam	F	G	S	T	U	R	F	G	S	T	U	R	F	G	S	T	U	R														
150×75×5.5	337	247	26	120	28 (18)	133																										
200×100×7	350	260	51	121	27 (17)	134	350	—	51	121	32 (27)	134	366	—	33	150	40	188														
250×125×7.5	363	273	76	124	24 (14)	137	363	—	76	124	29 (24)	137	379	—	58	153	37	200	379													
300×150×11.5							376	—	101	134	19 (14)	147	392	—	83	163	27	210	392													
450×175×11																		405	—													
Approx. weight (kg)	145				155				165				185				290				320				370				400			

NOTES : 1. () dimensions represent dimensions of 1/2HM6 and 1HM6 (Hoist type)
 2. Unless otherwise specified trolley is being assembled so as to meet smudged I-beam size.

Dimensions

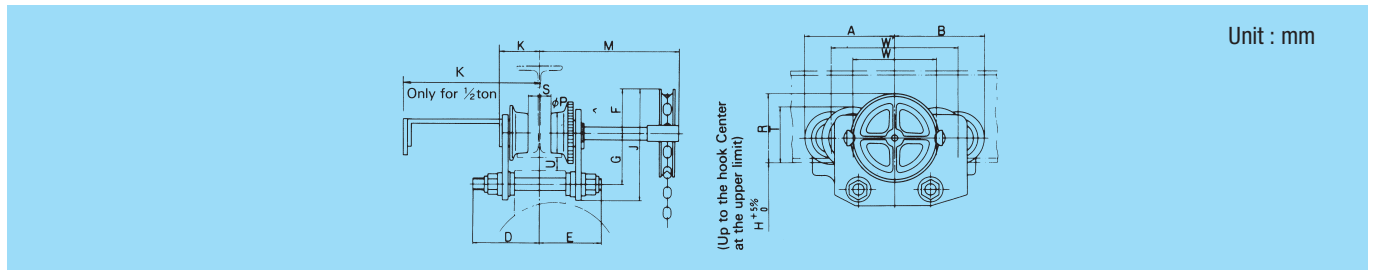

Table of Dimensions (This table applies to the standard headroom type. For the low headroom type, contact the nearest Hitachi Representative)

Model	1/2C5						1C5						2C5						3C5						
Capacity (t)	1/2						1						2						3						
Approx. dimensions (mm)	A	185						240						250						250					
	B	230						240						250						250					
	D	178						178						198						198					
	E	149						149						198						198					
	F	85						85						125						125					
	G	110						120						140						140					
	J	235						245						305						305					
	W/W'	189/240						189/350						231/350						231/350					
	φp	85						85						110						110					
H(Standard)	715						775						985						1,115						
Min. curve radius (m)	1.3						4.0						4.0						4.0						
Dimensions with respect to I-beam	K	M	R	S	T	U	K	M	R	S	T	U	K	M	R	S	T	U	K	M	R	S	T	U	
150×75×5.5	247	337	133	26	120	28 (18)																			
200×100×7	260	350	134	51	121	27 (17)	92	350	134	51	121	32 (27)	93	366	188	33	150	40							
250×125×7.5	273	363	137	76	124	24 (14)	105	363	137	76	124	29 (24)	106	379	200	58	153	37	106	379	200	58	153	37	
300×150×11.5							118	376	147	101	134	19 (14)	119	392	210	83	163	27	119	392	210	83	163	27	
450×175×11																			132	405	208	108	161	29	
Approx. weight (kg)	50						40						74						74						
Applicable hoist type	1/2(H)M6						1(H)M6						2(H)M7						3(H)M6						

NOTES : 1. Weight indicates empty weight of the trolley.
 2. Dimensions W represent the drive side while W' equals driven side.
 3. Unless otherwise specified trolley is being assembled so as to meet smudged I-beam size.
 4. () dimensions represent dimensions of 1/2HM6 and 1HM6 (Hoist type)

Outline

A-series

V-series

Others

Low Headroom Type Hoist

Being designed to enable to lift the load block up to the I-beam bottom, this hoist is suitable for handling bulky cargo under low-ceiling building.

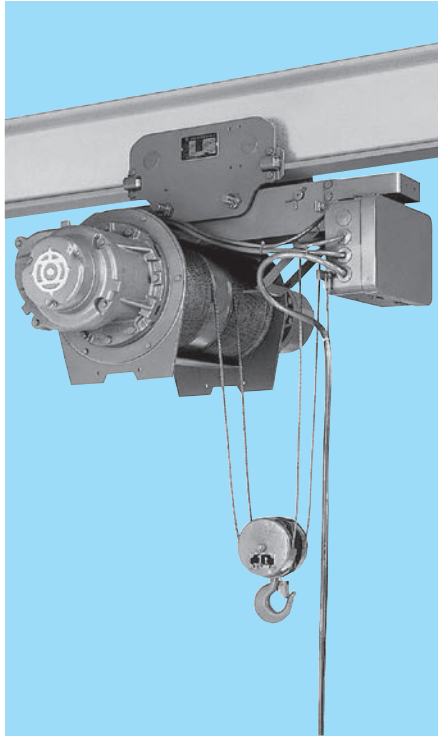

Specifications

Capacity (t)			1/2	1	2	3	5
Hoisting lift (m)			6	6 and 12			6
Hoisting	Speed (m/min)	50Hz	11	11	8.4	7.5	6.7
		60Hz	13	13	10	9	8
	Motor (kW)	50Hz	1.0	1.9	2.9	4.2	5.9
		60Hz	1.2	2.3	3.5	5	7
		No. of poles	4				
Traversing	Speed (m/min)	50Hz	21				
		60Hz	25				
	Motor (kW)	50Hz	0.30		0.45	0.63	
		60Hz	0.36		0.55	0.75	
		No. of poles	4				
Wire rope	No. of falls		4				
	Composition		6×W (19)-B			6×Fi (29)-B	
	Diam. (mm)		φ 4	φ 6.3	φ 8	φ 10	φ 12.5
Rating			40% ED 400 Starts/h				
Operating method			Push-button operation 				
Electric source (3 phase)			200V 50/60Hz, 220V 60Hz, 380-400V 50Hz, 415V 50Hz, 440-460V 60Hz				
Control voltage			200V 50/60Hz				

NOTE : 1. The suspension-type hoist and the hoist with chain-driven trolley will be produced on demand.

1/2L-T₅₅

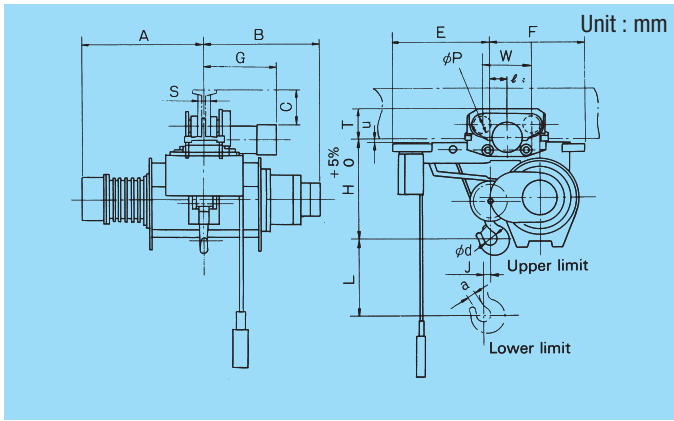

1L-T₅₅

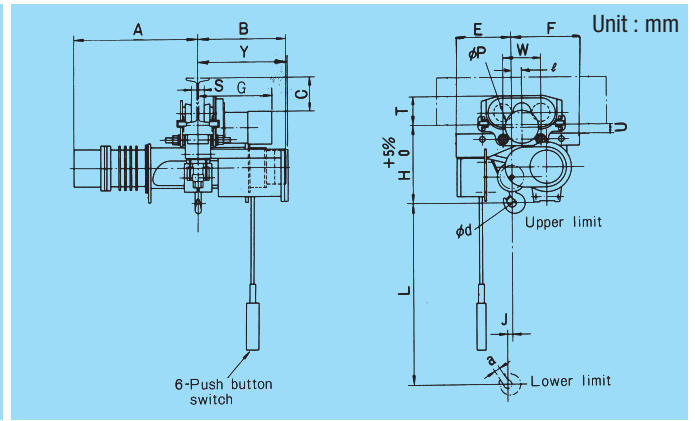

1HL-T₅₅, 2L-T₅₅, 3L-T₅₅

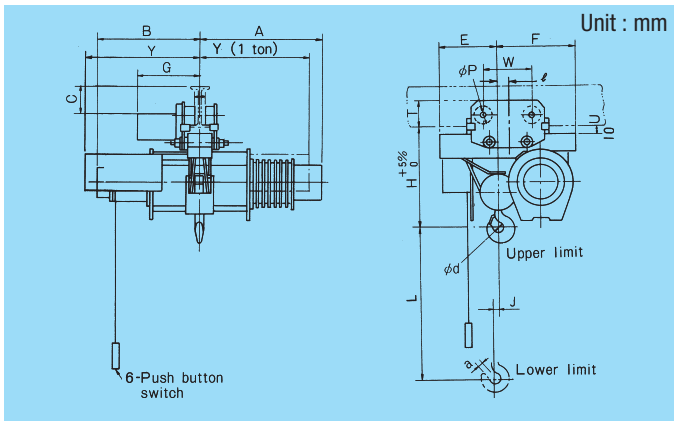

2HL-T₅₅, 3HL-T₅₅, 5L-T₅₅

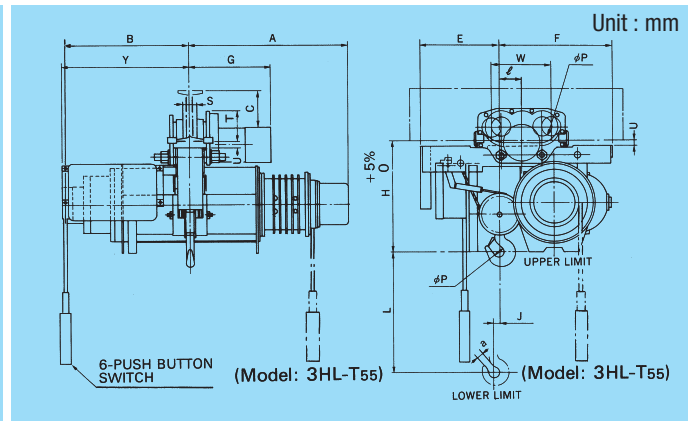

Table of Dimensions

Model	1/2L-T ₅₅					1L-T ₅₅					1HL-T ₅₅					2L-T ₅₅					2HL-T ₅₅					3L-T ₅₅					3HL-T ₅₅					5L-T ₅₅					
Hoist type	1/2L ₅					1L ₅					1HL ₅					2L ₅					2HL ₅					3L ₅					3HL ₅					5L ₅					
Trolley type	1/2T ₅					1T ₅					1T ₅					2T ₅					2T ₅					3T ₅					3HLT ₅					5T ₅					
Capacity (t)	1/2					1					1					2					2					3					3					5					
Approx. dimensions (mm)	L	6,000					6,000					12,000					6,000					12,000					6,000					12,000					6,000				
	H	400					425					450					515					520					600					650					810				
	A	550					665					675					705					785					785					830					845				
	B	430					475					560					540					635					600					700					690				
	W	200/290					200/290					200/290					200/290					230/310					230/410					250/330									
	E	410					295					325					365					380					400					480					610				
	F	340					360					465					480					565					575					660					680				
	ϕd	40					45					45					56					56					71					90									
	J	26					28					35					42					43					46					50					35				
	Y	—					555					555					630					630					620					620					700				
	ϕp	96					96					96					96					96					128					156/140(DRIVE SIDE/DRIVEN SIDE)									
	a	21					23					23					36					36					42					42					58				
ℓ	40					54					108					85					104					100					99					89					
Min. curve Radius (m)	1.3(5.0)					1.5					1.5					1.8					1.8					2.0					3.5					3.0					
Dimensions with respect to I-beam (mm)	S	T	U	C	G	S	T	U	C	G	S	T	U	C	G	S	T	U	C	G	S	T	U	C	G	S	T	U	C	G	S	T	U	C	G	S	T	U	C	G	
(150×75×5.5)	17	147	53	85	361																																				
200×100×7	42	148	52	135	374	42	148	52	135	374	42	148	32	135	378																										
250×125×7.5	67	151	49	185	387	67	151	49	185	387	67	151	29	185	391	52	177	28	180	417																					
300×150×11.5						92	160	40	225	400	92	160	20	225	404	77	187	18	220	430	77	225	23	215	450																
450×175×11																102	185	20	370	443	102	223	25	365	463																
Approx. weight (kg)	155					205					285					310					400					435					605					750					

NOTES : 1. Dimensions W represent dimensions of drive side/driven side.
 2. 1/2 ton-When an I-beam (150×75×5.5) is used, the minimum curve radius is 5m.
 3. 1/2 ton-When an I-beam (150×75×5.5) is used, 50mm-thick shims are necessary between the building and the I-beam.
 4. Unless otherwise specified trolley is being assembled so as to meet smudged I-beam size.

Outline

A-series

V-series

Others

Double-Rail Type Hoist

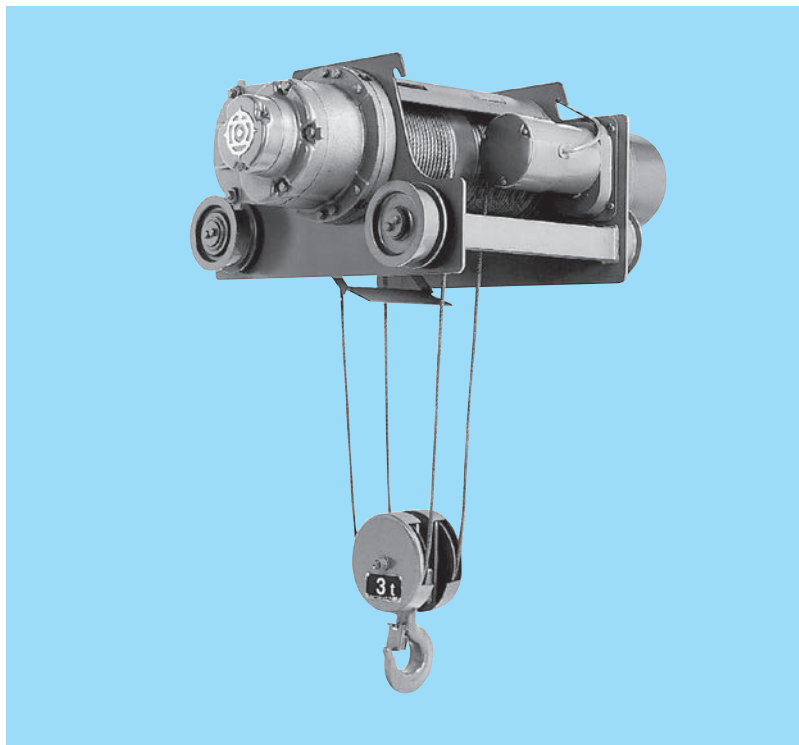

The double-rail hoist is ideally employed as an overhead traveling crane. Since the self-adjusting center core is adopted, the wheels closely follow the rails and are hard to derail during operation. The compact, dustproof structure occupies minimal space and requires less maintenance. Installation cost can be reduced.

Specifications

Capacity (t)			2	3	5	7.5	10	15	20	30
Hoisting lift (m)			12	6 and 12	8 and 12	8 and 12		8 and 12	12	12
Hoisting	Speed (m/min)	50Hz	8.4	7.5	6.7	6.0	5.0	5.0	4.2	2.8
		60Hz	10	9	8	7.2	6.0	6.0	5.0	3.3
	Motor (kW)	50Hz	2.9	4.2	5.9	7.9	8.8	6.7×2	7.5×2	7.5×2
		60Hz	3.5	5	7	9.5	10.5	8×2	9×2	9×2
No. of poles		4								
Traversing	Speed (m/min)	50Hz	21			14				
		60Hz	25			17				
	Motor (kW)	50Hz	0.30	0.45	0.45	0.45×2	0.45×2	0.45×2	0.45×2	0.7×2
		60Hz	0.36	0.55	0.55	0.55×2	0.55×2	0.55×2	0.55×2	0.84×2
No. of poles		4								
Wire rope	No. of falls		4						8	
	Composition		6×Fi (29)-B			6×Fi (29)-B		6×Fi (29)-B	6×Fi (29)IWRC-B	6×Fi (29)-B
	Diam. (mm)		φ 8	φ 10	φ 12.5	φ 14	φ 16	φ 20	φ 22.4	φ 20
Rating			40% ED 400 starts/h					40% ED 250 starts/h		
Operating method			Push-button operation 			Push-button operation 				
Electric source (3 phase)			200V 50/60Hz, 220V 60Hz, 380-400V 50Hz, 415V 50Hz, 440-460V 60Hz							
Control voltage			200V 50/60Hz							

Double-Rail Type Hoist

Dimensions

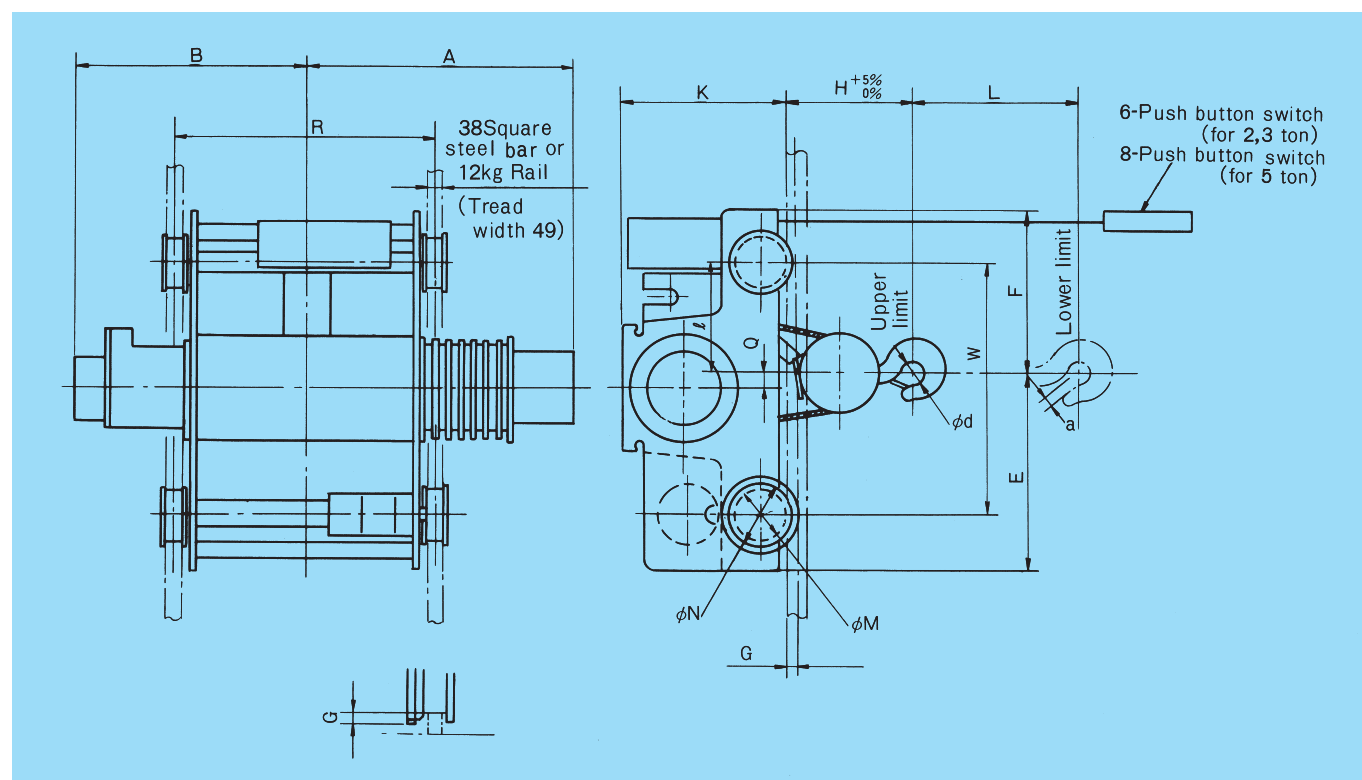

Table of Dimensions

Model		2HD-T ₅₅	3D-T ₅₅	3HD-T ₅₅	5D-T ₅₅	5HD-T ₅₅
Hoist type		2HD ₅	3D ₅	3HD ₅	5D ₅	5HD ₅
Trolley type		2DT ₅	3DT ₅	3DT ₅	5DT ₅	5DT ₅
Capacity (t)		2	3	3	5	5
Approx. dimensions (mm)	L	12,000	6,000	12,000	8,000	12,000
	H	310		360		560
	K	430		480		500
	R	900	650	950	900	1,150
	F	455		430		530
	E	425		450		550
	W	650		650		850
	A	835	755	915	845	955
	B	675	570	730	690	800
	φd	56		71		90
	Q	40		51		55
	φM	160		160		160
	φN	190		190		190
	G	26		26		26
ℓ	350		325		425	
a	36		42		58	
Rail (mm)		38 square steel bar or 12 kg rail				
Wheel tread width (mm)		49				
Approx. weight (kg)		380	420	490	680	750

Double-Rail Type Hoist

Dimensions

7.5, 10t

15, 20t

30t

Unit : mm

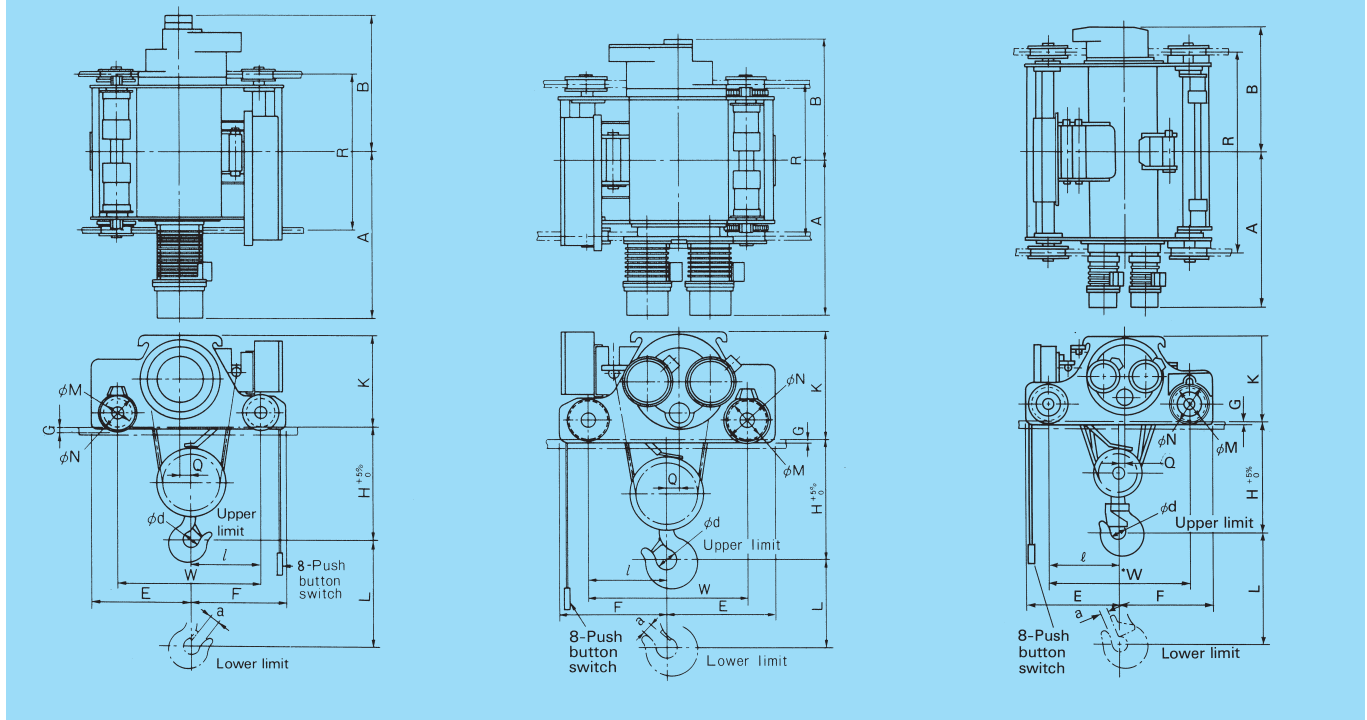
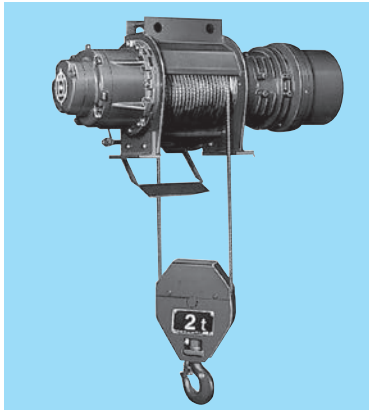

Table of Dimensions

Model	7.5D-T55	7.5HD-T55	10D-T55	10HD-T55	15D-T55	15HD-T55	20HD-T55	30HD-T55
Hoist type	7.5D ₅	7.5HD ₅	10D ₅	10HD ₅	15D ₅	15HD ₅	20HD ₅	30HD ₅
Trolley type	7.5DT ₅	7.5DT ₅	10DT ₅	10DT ₅	15DT ₅	15DT ₅	20DT ₅	30DT ₅
Capacity (t)	7.5		10		15		20	30
Approx. dimensions (mm)	L	8,000	12,000	8,000	12,000	8,000	12,000	12,000
	H	515		680		785		930
	K	600		600		730		850
	R	1,000	1,150	1,000	1,150	1,000	1,200	2,000
	F	605		615		700		905
	E	615		650		740		935
	W	865		915		1,040		1,400
	A	1,075	1,150	1,075	1,150	1,060	1,160	1,550
	B	830	905	885	960	750	850	1,250
	φd	100		100		130		165
	Q	67		70		89		65
	φM	195		195		250		350
	φN	225		225		282		400
	G	29		29		28		38
a	69		69		86		114	
ℓ	433		445		505		685	
Rail (mm)	44 square steel bar or 15 kg rail				55 square steel bar or 22 kg rail			
Wheel tread width (mm)	53		53		66		66	76
Approx. weight (kg)	1,070	1,130	1,260	1,350	2,150	2,250	2,450	4,400

Stationary Type Hoist

Dimensions



1/2, 1, 2, 3t

5t

Unit : mm

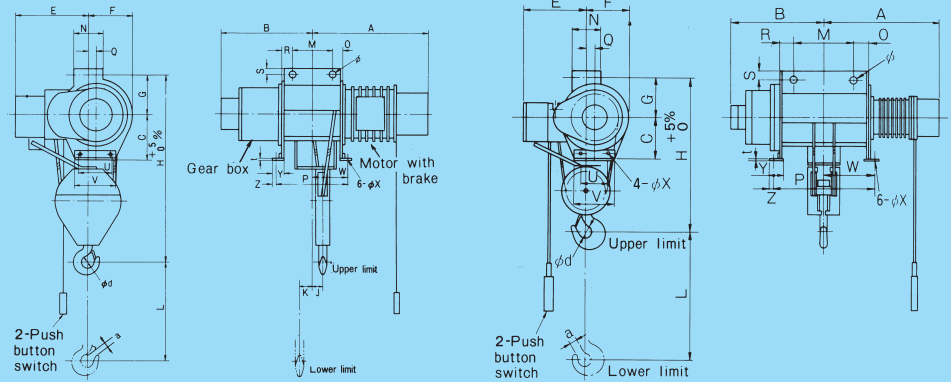

The motors with brake and the gearbox of 1/2, 1-ton type are reversed in this drawing.

Specifications

Specifications of the V-series standard headroom type hoist applicable, except for traveling.

Table of Dimensions

Model	1/2MW ₆	1/2HMW ₆	1MW ₆	1HMW ₆	2MW ₇	2HMW ₇	3MW ₆	3HMW ₆	5MW ₅	5HMW ₅	
Capacity (t)	1/2		1		2		3		5		
Approx. dimensions (mm)	L	6,000	12,000	6,000	12,000	6,000	12,000	6,000	12,000	8,000	12,000
	H	660		710		910		1,050		1,110	
	A	485	655	545	715	595	630	645	690	845	955
	B	355	380	350	385	435	615	475	665	690	800
	M	200		200		200		200		270	
	φ	26		26		36		36		46	
	N	114		139		139		164		189	
	E	335		345		415		460		455	
	F	190		255		220		245		305	
	φd	40		45		56		71		90	
	a	21		23		36		42		58	
	J	80	105	85	115	75	100	80	110	—	—
	K	20	110	20	90	30	110	35	120	—	—
	O	52	80	47	80	56	91	65	106	198	310
	R	52	230	47	217	58	237	79	262	198	310
	Q	25.5		32.5		35.5		41.5		52.5	
	S	30	40	35	40	35		35		50	
	U	180		180		180		260		260	
	V	240		265		265		320		320	
	C	242		242		312		342		315	
G	150		160		200		225		290		
P	379	582	372	575	392	606	424	648	745	970	
W	190	218	186	213	195	240	205	246	373	485	
Y	75		70		70		75		75		
Z	22		22		22		22		22		
t	12		12		12		12		12		
φX	18		18		18		18		18		
Approx. weight (kg)	105	115	135	155	255	295	345	385	560	620	

Stationary Type Hoist

Dimensions

Unit : mm

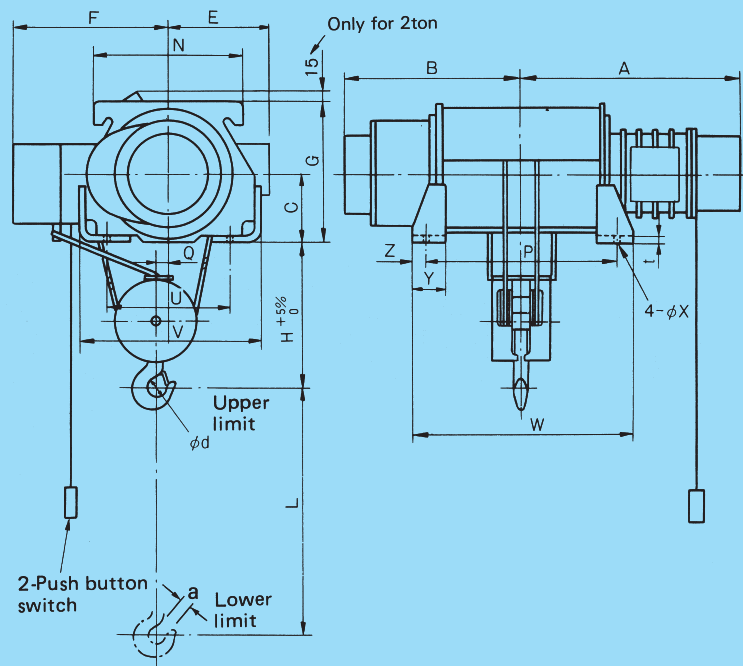

Table of Dimensions

Model		2HDW _s	3DW _s	3HDW _s	5DW _s	5HDW _s
Capacity (t)		2	3	3	5	5
Approx. dimensions (mm)	L	12,000	6,000	12,000	8,000	12,000
	H	390	445		580	
	A	890	785	950	845	955
	B	730	600	765	690	800
	E	225	238		278	
	F	445	475		540	
	C	171	195		245	
	G	355	395		485	
	N	340	400		420	
	P	980	730	1,030	748	998
	Q	40	51		55	
	U	300	300		380	
	V	450	476		556	
	W	1,040	790	1,125	994	1,218
	φX	26	26		26	
	Y	89	115		190	
	Z	30	30	47.5	123	110
	t	19	19		19	
φd	56	71		90		
a	36	42		58		
Approx. weight (kg)		260	340	390	600	665

Stationary Type Hoist

Dimensions

7.5, 10t

Unit : mm

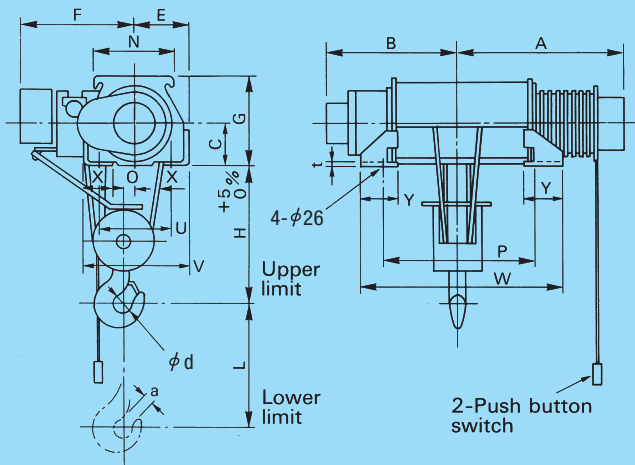

15, 20t

Unit : mm

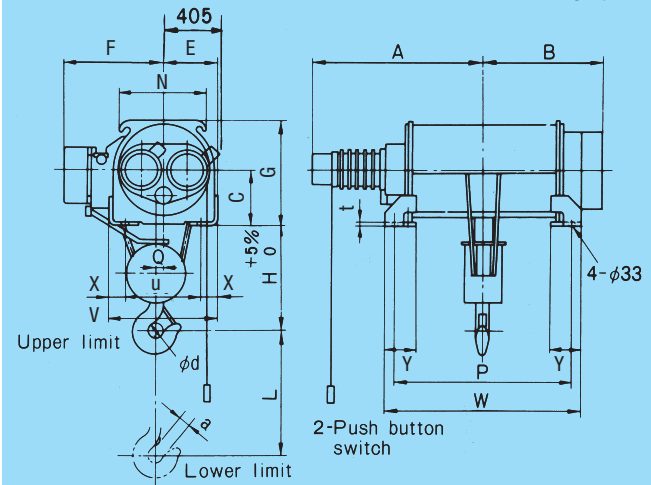
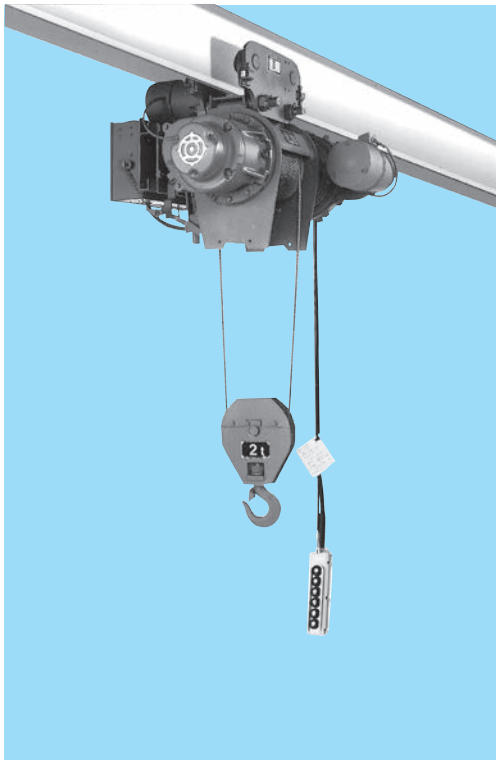

Table of Dimensions

Model	7.5DW _s	7.5HDW _s	10DW _s	10HDW _s	15DW _s	15HDW _s	20HDW _s
Capacity (t)	7.5		10		15	15	20
Approx. dimensions (mm)	L	8,000	12,000	8,000	12,000	8,000	12,000
	H	635		690		840	
	A	1,075	1,150	1,075	1,150	1,060	1,160
	B	830	905	885	960	750	850
	E	278		309		370	
	F	660		665		780	
	C	250		300		340	
	G	500		600		680	
	N	460		500		560	
	P	945	1,095	945	1,095	950	1,150
	Q	67		70		89	
	U	380		380		490	
	V	556		618		740	
	W	1,315	1,398	1,248	1,398	1,200	1,400
	X	148		179		200	
	Y	220	220	207	220	240	240
	φd	100				130	
t	19		19		22		22
a	69		69		86		108
Approx. weight (kg)	800	860	1,040	1,080	1,850	2,000	2,150

Hoist with Creep Speed for Hoisting



With their fine speed adjustment, Hitachi's hoists meet today's needs for safer and more accurate transfer work

Today's increasingly diversified transfer operations in the field are calling for hoists with functions for transferring loads with higher safety and efficiency. Our researchers, with their time-tested expertise in hoist manufacture, have come up with a new family of hoists incorporating fine speed adjustment capability. The novel hoists offer features that promise higher performance, better maintainability and longer life.

■ Specifications table

type			STANDARD-HEADROOM TYPE HOIST								
Capacity (t)			1/2	1	2	3	5	7.5	10	15	20
Hoisting lift (m)			6, 12				8, 12				12
Hoisting	Speed (m/min)	50Hz	11/1.1	11/1.1	8.4/0.84	7.5/0.75	6.7/0.67	6/0.6	5/0.5	5/0.5	4.2/0.42
		60Hz	13/1.3	13/1.3	10/1	9/0.9	8/0.8	7.2/0.72	6/0.6	6/0.6	5/0.5
	Motor (kW)	50Hz	1/0.1	1.9/0.19	2.9/0.29	4.2/0.42	5.9/0.59	7.9/1.0	8.8/1.0	6.7/1.1×2	7.5/1.0×2
		60Hz	1.2/0.12	2.3/0.23	3.5/0.35	5/0.5	7/0.7	9.5/1.2	10.5/1.2	8/1.2×2	9/1.2×2
No. of poles		4/4									
Traversing	Speed (m/min)	50Hz	21				14		14		
		60Hz	25				17		17		
	Motor (kW)	50Hz	0.30	0.30	0.30	0.45	0.63	0.47×2	0.47×2	0.7×2	0.7×2
		60Hz	0.36	0.36	0.36	0.55	0.75	0.56×2	0.56×2	0.84×2	0.84×2
No. of poles		4				6		4			
Wire rope	No. of falls		2				4				
	Composition		6×W(19)-B		6×Fi(29)-B						6×Fi(29)IWRC-B
	Diam.(mm)		φ6.3	φ8	φ11.2	φ14	φ12.5	φ14	φ16	φ20	φ22.4

Standard specifications

- Power source
3-phase 200V 50/60Hz, 220V 60Hz, 380V-400V 50Hz, 415V 50Hz, 440-460 60Hz
- Operating method
By 6 pushbuttons on the floor : ⬆️ ⬇️ ⬅️ ➡️ ⬇️⬆️ and ⬆️⬇️
(2-step motion on ⬆️⬇️ and ⬆️⬇️, 1st step for creep speed and 2nd step for standard speed)
8 pushbuttons on 5t double rail type and 7.5t or greater
- Rating
30 minutes (as specified by JIS C9620)
400 starts/hr (250 starts/hr) 40% ED (40% ED)
Those in parentheses are for 15t or greater.
- Power feed method
By cable or collector (The cable and collector are not provided.)
- Structure
Indoor type. Install a shelter with roof to avoid rain falling on the hoist when using it outdoors.
- Ambient temperature
-10°C to 40°C
- Humidity
Up to 90% (No condensation)
- Applicable standard
Structural Code for Cranes (Japan)

Type identification

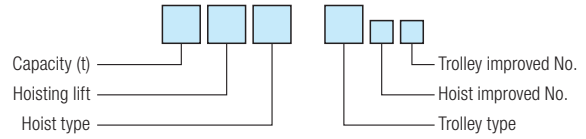

Capacity	Hoisting lift		Hoist type	Trolley type
	Low lift	High lift		
Rated load indicated by tons	No mark	H	V-series Standard headroom type ······MC Low headroom type ······LC Double rail type ······DC	Manual driven trolley ······P Chain driven trolley ······C Motorized trolley ······T

Example

2t high-lift normal type hoist with UP (DOWN) creep speed



NOTE : The machine type is separately made for the hoist and trolley.
Example : Nameplate of hoist : 2HMC7
Nameplate of trolley : 2Ts

LOW-HEADROOM TYPE HOIST					DOUBLE-RAIL TYPE HOIST								
1/2	1	2	3	5	2	3	5	7.5	10	15	20	30	
6	6, 12			6	12	6, 12	8, 12			12			
11/1.1	11/1.1	8.4/0.84	7.5/0.75	6.7/0.67	8.4/0.84	7.5/0.75	6.7/0.67	6/0.6	5/0.5	5/0.5	4.2/0.42	2.8/0.28	
13/1.3	13/1.3	10/1	9/0.9	8/0.8	10/1	9/0.9	8/0.8	7.2/0.72	6/0.6	6/0.6	5/0.5	3.3/0.33	
1/0.1	1.9/0.19	2.9/0.29	4.2/0.42	5.9/0.59	2.9/0.29	4.2/0.42	5.9/0.59	7.9/1	8.8/1	6.7/1×2	7.5/1×2	7.5/1×2	
1.2/0.12	2.3/0.23	3.5/0.35	5/0.5	7/0.7	3.5/0.35	5/0.5	7/0.7	9.5/1.2	10.5/1.2	8/1.2×2	9/1.2×2	9/1.2×2	
4/4					4/4								
21					21				14				
25					25				17				
0.30	0.30	0.30	0.45	0.63	0.30	0.45	0.45	0.45×2	0.45×2	0.45×2	0.45×2	0.70×2	
0.36	0.36	0.36	0.55	0.75	0.36	0.55	0.55	0.55×2	0.55×2	0.55×2	0.55×2	0.84×2	
4					4				4				
4					4				8				
6×W(19)-B		6×Fi(29)-B			6×Fi(29)-B				6×Fi(29)-B			6×Fi(29)IWRC-B	6×Fi(29)-B
φ4	φ6.3	φ8	φ10	φ12.5	φ8	φ10	φ12.5	φ14	φ16	φ20	φ22.4	φ20	

Ultra High Lift Type Hoist

Standard Type Hoist / Hoist with Motorized Trolley (1 – 5t)

Dimensions

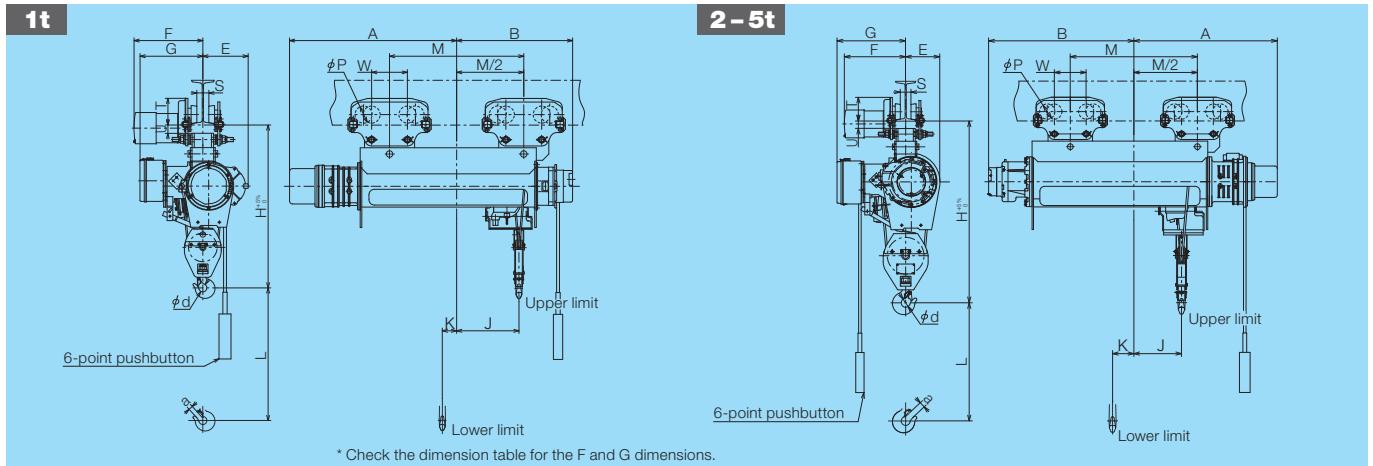

Specifications Table

Model	1MU-T ₆₅				2MU-T ₇₅				3MU-T ₆₅				5MU-T ₆₅													
Hoist type	1MU ₆				2MU ₇				3MU ₆				5MU ₆													
Trolley type	½T ₅ ×2				1T ₅ ×2				2T ₅ ×2				3T ₅ ×2													
Rated load (t)	1				2				3				5													
Lift (m)	24		36		24		36		24		36		24		36											
Hoisting speed (m/min)	50Hz		11		8.4		7.5		6.7																	
	60Hz		13		10		9.0		8.0																	
Hoisting motor (kW)	50Hz		1.9		2.9		4.2		5.9																	
	60Hz		2.3		3.5		5.0		7.0																	
Traversing speed (m/min)	50Hz				21				25																	
	60Hz				25				21																	
Traversing motor (kW)	50Hz		0.30×2		0.30×2		0.30×2		0.45×2																	
	60Hz		0.36×2		0.36×2		0.36×2		0.55×2																	
Electric source (3-phase)	200V 50/60Hz, 220V 60Hz, 380-400V 50Hz, 415V 50Hz, 440-460V 60Hz																									
Rating	40%ED, 400starts/h																									
No. of falls - Diameter (mm) and [Composition] of the wire rope	2- φ 8 [4×F(40)-B]				2- φ 11.2 [4×F(40)-B]				2- φ 14 [6×37-A]				2- φ 18 [6×37-A]													
Approx. weight (kg)	L		385		440		475		605		645		760		1,140		1,250									
	24,000		36,000		24,000		36,000		24,000		36,000		24,000		36,000		36,000									
Approx. dimensions (mm)	H				900/(950)				1,140/(1,190)				1,250/(1,330)				1,490/(1,600)									
	A		935		1,125		905		1,115		950		1,180		1,080		1,310									
	B		650		875		915		1,045		920		1,150		935		1,175									
	E				255				220				245				325									
	G				355				425				470				550									
	J		348		573		300		490		346		576		400		633									
	K		80		52		134		153		120		122		70		77									
	M				750				1,200				800				1,220									
	W				200/290				200/290				200/290				230/310									
	φ d				45				56				71				90									
	a				23				36				42				58									
	φ p				96				96				96				128									
Clearance to I-beam (mm)	F		S		T		U		F		S		T		U		F		S		T		U			
	200×100×7		374		42		148		47		—		—		—		—		—		—		—			
	250×125×7.5		387		67		151		44		387		67		151		44		393		67		153		39	
	300×150×11.5		—		—		—		—		400		92		160		35		406		92		163		29	
	450×175×11		—		—		—		—		—		—		—		—		—		—		—		—	
Min. curve radius (m)	Straight line (1.5)				Straight line (1.8)				Straight line (2.0)				Straight line (3.0)													

NOTES : 1. The number in parentheses of dimension H stands for the I-beam bending curve.
 2. The number in parentheses of the Min. curve radius indicates the minimum radius of the I-beam bending curve.
 3. The ultra high lift type for straight lines cannot be used for curved lines.
 4. The numbers in dimension W indicate the values for the driving side/driven side.
 5. Unless otherwise specified, the product is delivered in the I-beam dimension of .
 6. If the rail contains curves, please notify us.

Ultra High Lift Type Hoist

Hoist with Motorized Trolley (7.5–20t)

Dimensions

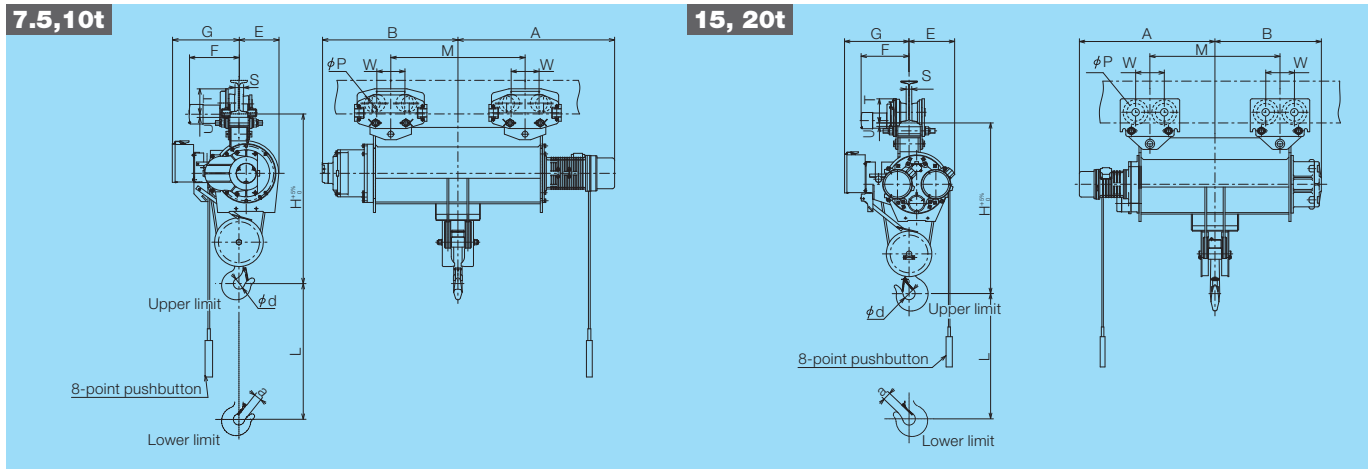

Specifications Table

Model	7.5MU-T55				10MU-T55				15MU-T56				20MU-T56				
Hoist type	7.5MU5				10MU5				15MU5				20MU5				
Trolley type	4FT5×2				5FT5×2				10AT5×2				10AT5×2				
Rated load (t)	7.5				10				15				20				
Lift (m)	20		30		20		30		20		30		20		30		
Hoisting speed (m/min)	50Hz		6.0		5.0		6.0		5.0		6.0		4.2		5.0		
	60Hz		7.2		6.0		10.5		8.0×2		9.0×2						
Hoisting motor (kW)	50Hz		7.9		8.8		6.7×2		7.5×2								
	60Hz		9.5		10.5		8.0×2		9.0×2								
Traversing speed (m/min)	50Hz				14				60Hz				17				
	60Hz				17				14				17				
Traversing motor (kW)	50Hz		0.47×2		0.47×2		0.7×2		0.7×2								
	60Hz		0.56×2		0.56×2		0.84×2		0.84×2								
Electric source (3-phase)	200V 50/60Hz, 220V 60Hz, 380-400V 50Hz, 415V 50Hz, 440-460V 60Hz																
Rating	40%ED, 400starts/h								40%ED, 250starts/h								
No. of falls - Diameter (mm) and [Composition] of the wire rope	4- φ 14 [6×Fi(29)-B]				4- φ 16 [6×Fi(29)-B]				4- φ 20 [6×Fi(29)-B]				4- φ 22.4 [6×Fi(29)-B]IWRC				
Approx. weight (kg)	1,450		1,650		1,870		2,470		3,700		4,200		3,900		4,600		
Approx. dimensions (mm)	L	20,000		30,000		20,000		30,000		20,000		30,000		20,000		30,000	
	H	1,345		1,345		1,515		1,515		1,865		1,865		2,010		2,010	
	A	1,400		1,650		1,410		1,660		1,455		1,760		1,550		1,890	
	B	1,160		1,410		1,220		1,470		1,140		1,450		1,250		1,590	
	E	320		320		360		360		500		500		500		500	
	G	600		600		600		600		705		705		705		705	
	M	1,200		1,700		1,200		1,700		1,400		2,000		1,530		2,180	
	W	230/310		230/310		250/330		250/330		309/309		309/309		309/309		309/309	
	φ d	100		100		100		100		130		130		165		165	
	a	69		69		69		69		86		86		108		108	
φ p	128		128		156/140		156/140		190		190		190		190		
Clearance to I-beam (mm)	F	S	T	U	F	S	T	U	F	S	T	U	F	S	T	U	
450×175×11	453	102	184	30	460	102	225	30	524	62	280	30	524	62	280	30	
600×190×13	461	117	189	25	468	117	230	25	532	77	285	25	532	77	285	25	
Min. curve radius (m)	Straight line				Straight line				Straight line				Straight line				

NOTES : 1. The numbers in dimension W indicate the values for the driving side/driven side.
 2. Please contact us when the rail contains curves.
 3. Unless otherwise specified, the product is delivered in the I-beam dimension of .

Outline

A-series

V-series

Others

Ultra High Lift Type Hoist

Double Rail Type Hoist (2–5t)

Dimensions

2–5t

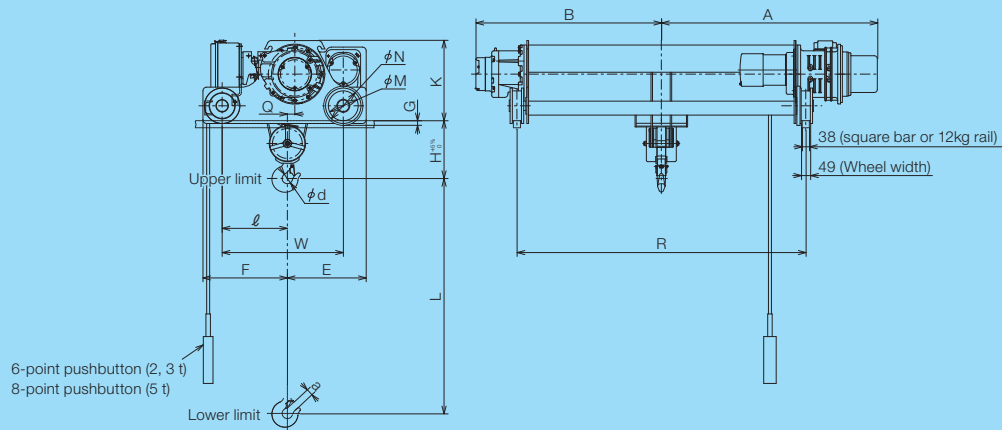

Specifications Table

Model	2DU-T55		3DU-T55		5DU-T55	
Hoist type	2DU ₅		3DU ₅		5DU ₅	
Trolley type	2DT ₅		3DT ₅		5DT ₅	
Rated load (t)	2		3		5	
Lift (m)	20		20		20	
Hoisting speed (m/min)	50Hz	8.4	7.5		6.7	
	60Hz	10	9.0		8.0	
Hoisting motor (kW)	50Hz	2.9	4.2		5.9	
	60Hz	3.5	5.0		7.0	
Traversing speed (m/min)	50Hz		21			
	60Hz		25			
Traversing motor (kW)	50Hz		0.45		0.45	
	60Hz		0.55		0.55	
Electric source (3-phase)	200V 50/60Hz, 220V 60Hz, 380-400V 50Hz, 415V 50Hz, 440-460V 60Hz					
Rating	40% ED, 400 starts/h					
No. of falls - Diameter (mm) and [Composition] of the wire rope	4- φ 8 [6×Fi(29)-B]		4- φ 10 [6×Fi(29)-B]		4- φ 12.5 [6×Fi(29)-B]	
Approx. weight (kg)	560		700		1,100	
Approx. dimensions (mm)	L	20,000	20,000		20,000	
	H	310	360		560	
	K	430	480		500	
	R	1,550	1,550		1,850	
	F	455	430		530	
	E	425	450		550	
	W	650	650		850	
	A	1,170	1,215		1,320	
	B	1,010	1,030		1,165	
	φ d	56	71		90	
	Q	40	51		55	
	φ M	160	160		160	
	φ N	190	190		190	
	G	26	26		26	
	l	350	325		425	
a	36	42		58		
Square rail (mm)	38 square bar or 12kg rail					
Wheel width (mm)	49		49		49	

Ultra High Lift Type Hoist

Double Rail Type Hoist (7.5–20t)

Dimensions

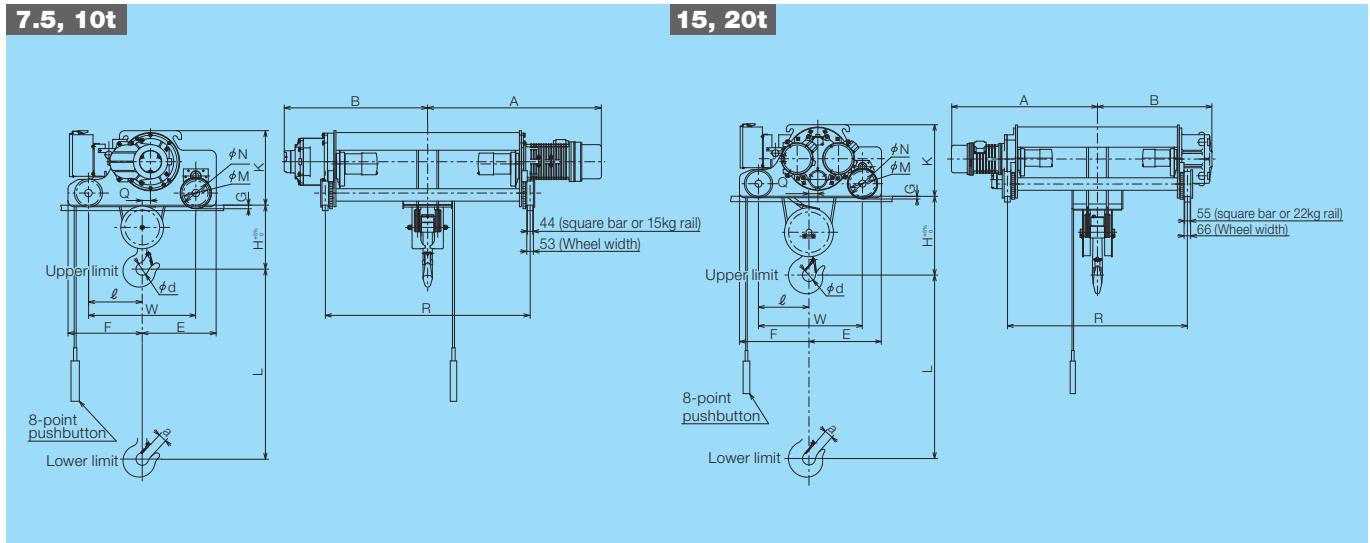

Specifications Table

Model	7.5DU-T ₅₅		10DU-T ₅₅		15DU-T ₅₅		20DU-T ₅₅		
Hoist type	7.5DU ₅		10DU ₅		15DU ₅		20DU ₅		
Trolley type	7.5DT ₅		10DT ₅		20DT ₅		20DT ₅		
Rated load (t)	7.5	7.5	10	10	15	15	20	20	
Lift (m)	20	30	20	30	20	30	20	30	
Hoisting speed (m/min)	50Hz	6.0	6.0	5.0	5.0	5.0	4.2	4.2	
	60Hz	7.2	7.2	6.0	6.0	6.0	5.0	5.0	
Hoisting motor (kW)	50Hz	7.9	7.9	8.8	8.8	6.7×2	6.7×2	7.5×2	
	60Hz	9.5	9.5	10.5	10.5	8.0×2	8.0×2	9.0×2	
Traversing speed (m/min)	50Hz	14							
	60Hz	17							
Traversing motor (kW)	50Hz	0.45×2	0.45×2	0.45×2	0.45×2	0.45×2	0.45×2	0.45×2	
	60Hz	0.55×2	0.55×2	0.55×2	0.55×2	0.55×2	0.55×2	0.55×2	
Electric source (3-phase)	200V 50/60Hz, 220V 60Hz, 380-400V 50Hz, 415V 50Hz, 440-460V 60Hz								
Rating	40% ED, 400 starts/h				40% ED, 250 starts/h				
No. of falls - Diameter (mm) and [Composition] of the wire rope	4- φ 14 [6×Fi(29)-B]		4- φ 16 [6×Fi(19)-B]		4- φ 20 [6×Fi(29)-B]		4- φ 22.4 [6×Fi(29)IWRC-B]		
Approx. weight (kg)	1,500	1,650	1,700	1,810	2,940	3,200	3,000	3,800	
Approx. dimensions (mm)	L	20,000	30,000	20,000	30,000	20,000	30,000	20,000	30,000
	H	515	515	680	680	785	785	930	930
	K	600	600	600	600	730	730	730	730
	R	1,650	2,150	1,650	2,150	1,800	2,400	1,950	2,600
	F	605	605	615	615	700	700	700	700
	E	615	615	650	650	740	740	740	740
	W	865	865	915	915	1,040	1,040	1,040	1,040
	A	1,400	1,650	1,405	1,660	1,460	1,760	1,550	1,890
	B	1,155	1,400	1,210	1,470	1,150	1,450	1,250	1,590
	φ d	100	100	100	100	130	130	165	165
	Q	67	67	70	70	89	89	91	91
	φ M	195	195	195	195	250	250	250	250
	φ N	225	225	225	225	282	282	282	282
	G	29	29	29	29	28	28	28	28
	ℓ	433	433	445	445	505	505	505	505
a	69	69	69	69	86	86	108	108	
Square rail (mm)	44 square bar or 15kg rail				55 square bar or 22kg rail				
Wheel width (mm)	53	53	53	53	66	66	66	66	

Outline

A-series

V-series

Others

Pair Hoist

(7.5, 10t)

Dimensions

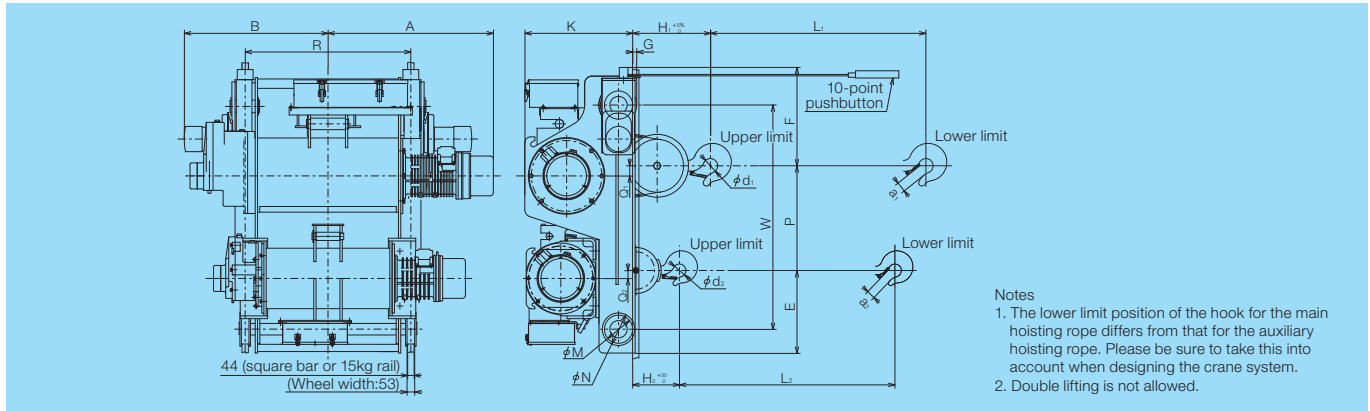

Specifications Table

Model		7.5D/2HD-T555	7.5HD/2HD-T555	7.5D/3HD-T555	7.5HD/3HD-T555	10D/2HD-T555	10HD/2HD-T555	10D/3HD-T555	10HD/3HD-T555	10D/5D-T555	10HD/5HD-T555										
Hoist type		7.5D _s	7.5HD _s	7.5D _s	7.5HD _s	10D _s	10HD _s	10D _s	10HD _s	10D _s	10HD _s										
Hoist type		2HDWZ _s	2HDWZ _s	3HDWZ _s	3HDWZ _s	2HDWZ _s	2HDWZ _s	3HDWZ _s	3HDWZ _s	5DWZ _s	5HDWZ _s										
Trolley type		7.5/2DT _s		7.5/3DT _s		10/2DT _s		10/3DT _s		10/5DT _s											
Main rope	Rated load (t)	7.5				10															
	Lift (m)	8	12	8	12	8	12	8	12	8	12										
	Speed (m/min)	50Hz	6.0				5.0														
			60Hz	7.2				6.0													
	Motor (kW)	50Hz		7.9				8.8													
			60Hz	9.5				10.5													
No. of poles	4				4																
No. of falls - Diameter (mm) [Composition]	4- φ 14 [6×Fi(29)-B]				4- φ 14 [6×Fi(29)-B]																
Auxiliary rope	Rated load (t)	2		3		2		3		5											
	Lift (m)	8	12	8	12	8	12	8	12	8	12										
	Speed (m/min)	50Hz	8.4		7.5		8.4		7.5		6.7										
			60Hz	10		9.0		10		9.0		8.0									
	Motor (kW)	50Hz		2.9		4.2		2.9		4.2		5.9									
			60Hz	3.5		5.0		3.5		5.0		7.0									
No. of poles	4			4		4		4		4											
No. of falls - Diameter (mm) [Composition]	4- φ 8 [6×Fi(29)-B]		4- φ 10 [6×Fi(29)-B]		4- φ 8 [6×Fi(29)-B]		4- φ 10 [6×Fi(29)-B]		4- φ 12.5 [6×Fi(29)-B]												
Traversing	Speed (m/min)	50Hz	14				14														
		60Hz	17				17														
	Motor (kW)	50Hz	0.45×2						0.45×2												
			60Hz	0.55×2						0.55×2											
	No. of poles	4						4													
Rating	40% ED, 400 starts/h																				
Electric source (3-phase)	200V 50/60Hz, 220V 60Hz, 380-400V 50Hz, 415V 50Hz, 440-460V 60Hz																				
Operation method	Above-floor 10-point pushbutton (ON, OFF, Main UP, Main DN, Aux. UP, Aux. DN, East, West, South, North)																				
Approx. weight (kg)	1,600		1,660		1,690		1,750		1,710		1,800		1,800		2,100		1,830		2,160		
Approx. dimensions (mm)	L ₁	8,000		12,000		8,000		12,000		8,000		12,000		8,000		12,000		8,000		12,000	
	L ₂	8,000		12,000		8,000		12,000		8,000		12,000		8,000		12,000		8,000		12,000	
	H ₁	415				540															
	H ₂	145		195		135		195		325											
	K	750				750															
	R	1,000	1,150	1,000	1,150	1,000	1,150	1,000	1,150	1,000	1,150										
	F	675	675	675	675	675	675	675	675	675	675										
	E	635	635	645	645	635	635	645	645	630	630										
	P	710				720		710		725											
	W	1,550				1,550															
	A	1,075	1,150	1,075	1,150	1,075	1,150	1,075	1,150	1,075	1,150										
	B	935	1,010	935	1,010	935	1,010	935	1,010	935	1,010										
	φ d ₁	100				100															
	a ₁	69				69															
	φ d ₂	56		71		56		71		90											
	a ₂	36		42		36		42		58											
	Q ₁	67				70															
	Q ₂	40		51		40		51		55											
φ M	195				195																
φ N	225				225																
G	29				29																
Square rail	44 square bar or 15kg rail				44 square bar or 15kg rail																
Wheel width (mm)	53				53																

Pair Hoist

(15 t, 20t)

Dimensions

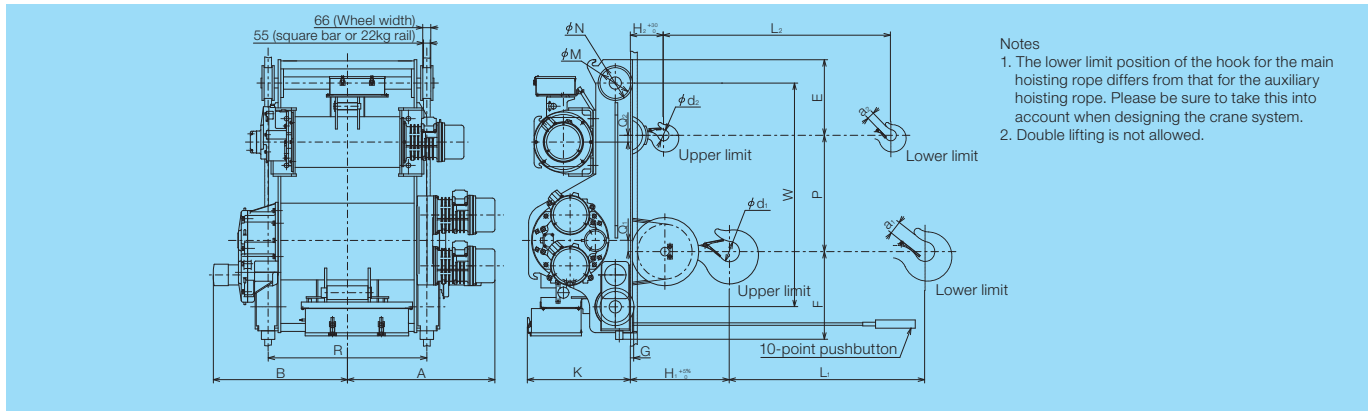

- Notes
1. The lower limit position of the hook for the main hoisting rope differs from that for the auxiliary hoisting rope. Please be sure to take this into account when designing the crane system.
 2. Double lifting is not allowed.

Specifications Table

Model		15D/2HD-T555	15HD/2HD-T555	15D/3HD-T555	15HD/3HD-T555	15D/5D-T555	15D/5HD-T555	20HD/2HD-T555	20HD/3HD-T555	20HD/5HD-T555									
Hoist type		15D ₅	15HD ₅	15D ₅	15HD ₅	15D ₅	15HD ₅	20HD ₅	20HD ₅	20HD ₅									
Hoist type		2HDW ₅	2HDW ₅	3HDW ₅	3HDW ₅	5DW ₅	5HDW ₅	2HDW ₅	3HDW ₅	5HDW ₅									
Trolley type		15/2DT ₅	15/2DT ₅	15/3DT ₅	15/3DT ₅	15/5DT ₅	15/5DT ₅	20/2DT ₅	20/3DT ₅	20/5DT ₅									
Main rope	Rated load (t)	15							20										
	Lift (m)	8	12	8	12	8	12	12											
	Speed (m/min)	50Hz		5.0		5.0		4.2											
		60Hz		6.7		6.7		5.0											
	Motor (kW)	50Hz		6.7×2		6.7×2		7.5×2											
60Hz		8.0×2		8.0×2		9.0×2													
No. of poles	4							4											
No. of falls - Diameter (mm) [Composition]	4- φ 20 [6×Fi(29)-B]							4- φ 22.4 [6×Fi(29)-IWRC-B]											
Auxiliary rope	Rated load (t)	2		3		5		2	3	5									
	Lift (m)	8	12	8	12	8	12	12											
	Speed (m/min)	50Hz		7.5		6.7		8.4	7.5	6.7									
		60Hz		9.0		8.0		10	9.0	8.0									
	Motor (kW)	50Hz		4.2		5.9		2.9	4.2	5.9									
60Hz		5.0		7.0		3.5	5.0	7.0											
No. of poles	4		4		4		4	4	4										
No. of falls - Diameter (mm) [Composition]	4- φ 8 [6×Fi(29)-B]		4- φ 10 [6×Fi(29)-B]		4- φ 12.5 [6×Fi(29)-B]		4-φ8 [6×Fi(29)-B]	4-φ10 [6×Fi(29)-B]	4-φ12.5 [6×Fi(29)-B]										
Traversing	Speed (m/min)	50Hz		14		14		14											
		60Hz		17		17		17											
	Motor (kW)	50Hz		0.45×2		0.45×2		0.45×2											
		60Hz		0.55×2		0.55×2		0.55×2											
Rating	40% ED, 250 starts/h							4											
Electric source (3-phase)	200V 50/60Hz, 220V 60Hz, 380-400V 50Hz, 415V 50Hz, 440-460V 60Hz																		
Operation method	Above-floor 10-point pushbutton (ON, OFF, Main UP, Main DN, Aux. UP, Aux. DN, East, West, South, North)																		
Approx. weight (kg)	2,730		2,810		2,830		2,930		3,010		3,170		3,140		3,260		3,500		
Approx. dimensions (mm)	L ₁	8,000		12,000		8,000		12,000		8,000		12,000		12,000		12,000		12,000	
	L ₂	8,000		12,000		8,000		12,000		8,000		12,000		12,000		12,000		12,000	
	H ₁	665							810										
	H ₂	80			140			270			75		140		270				
	K	850							850										
	R	1,000		1,200		1,000		1,200		1,000		1,200		1,300					
	F	720			720			720			720								
	E	655		680		675		675		620		680		675					
	P	965		940		945		945		940		940		945					
	W	1,820							1,820										
	A	1,060		1,160		1,060		1,160		1,060		1,160		1,210					
	B	950		1,050		950		1,050		950		1,050		1,100					
	φ d ₁	130							165										
	a ₁	86							108										
	φ d ₂	56		71		90		56		71		90							
	a ₂	36		42		58		36		42		58							
	Q ₁	89		89		89		89		91		91							
Q ₂	40		51		55		40		51		55								
φ M	250							250											
φ N	282							282											
G	28							28											
Square rail	55 square bar or 22kg rail							55 square bar or 22kg rail											
Wheel width (mm)	66							66											

NOTE : 1. Models of 30t,40t and 50t will be produced on demand.

Special Hoisting Speed Type Hoist

Specifications Table

50Hz

(Unit: m/min)

Rated load (t)	Standard speed	Low-speed hoisting		High-speed hoisting		* Dual-speed hoisting					
		Half (1/2 speed)	Creep (1/4 speed)	Fast (×1.5 speed)	Fast (×2 speed)	Standard / 1/10 speed (10 : 1)	Standard / 1/2 speed (2 : 1)	Half / 1/10 speed (5 : 1)	Half / 1/20 speed (10 : 1)	Standard ×1.5 / 0.75 speed (2 : 1)	Standard ×2 / standard speed (2 : 1)
1/2	11	5.5	—	—	—	11/1.1	11/5.5	5.5/1.1	5.5/0.55	—	—
1	11	5.5	2.8	16.8	22	11/1.1	11/5.5	5.5/1.1	5.5/0.55	16.8/8.4	22/11
2	8.4	4.2	2.1	11	15	8.4/0.84	8.4/4.2	4.2/0.84	4.2/0.42	11/5.5	15/7.5
3	7.5	3.7	1.9	11	15	7.5/0.75	7.5/3.7	3.7/0.75	3.7/0.37	11/5.5	15/7.5
5	6.7	3.4	1.7	—	10	6.7/0.67	6.7/3.4	3.4/0.67	3.4/0.34	—	10/5.0
7.5	6.0	3.0	1.5	—	10	6.0/0.6	6.0/3.0	3.0/0.60	3.0/0.30	—	—
10	5.0	2.5	1.2	7.3	—	5.0/0.5	5.0/2.5	2.5/0.50	2.5/0.25	—	—
15	5.0	2.5	1.2	—	—	5.0/0.5	5.0/2.5	2.5/0.50	2.5/0.25	—	—
20	4.2	2.1	1.0	—	—	4.2/0.42	4.2/2.1	2.1/0.42	2.1/0.21	—	—
30	2.8	1.4	—	—	—	2.8/0.28	2.8/1.4	1.4/0.28	1.4/0.14	—	—

NOTE : 1: * Indicates two-step operation.

Special Traverse Speed Type Hoist

Specifications Table

50Hz

(Unit: m/min)

Rated load (t)	Standard speed	Low-speed traversing		High-speed traversing	* Dual-speed traversing		
		Slow	Creep (1/4 speed)		Standard / 1/4 speed (4 : 1)	Standard / half speed (2 : 1)	Standard ×2 / standard speed (2 : 1)
1/2	21	10.5	5.0	—	21/5.0	21/10.5	42/21
1	21	10.5	5.0	—	21/5.0	21/10.5	42/21
2	21	10.5	5.0	—	21/5.0	21/10.5	42/21
3	21	10.5	5.0	—	21/5.0	21/10.5	42/21
5	21	10.5	5.0	—	21/5.0	21/10.5	42/21
*7.5	14	10.5 7.0	3.5	21	14/3.5	21/10.5 14/7	—
*10	14	10.5 7.0	3.5	21	14/3.5	21/10.5 14/7	—
15	14	7.0	3.5	—	14/3.5	14/7.0	—
20	14	7.0	3.5	—	14/3.5	14/7.0	—
*30	14	7.0	3.5	—	14/3.5	14/7.0	—

NOTE : 1: * 7.5, 10 (tons): The upper stage is of the standard type, and the lower stage is of the double rail type.
2: * 30 (tons): Available only for the double rail type.

Specifications Table

60Hz

(Unit: m/min)

Rated load (t)	Standard speed	Low-speed hoisting		High-speed hoisting		* Dual-speed hoisting					
		Half (1/2 speed)	Creep (1/4 speed)	Fast (×1.5 speed)	Fast (×2 speed)	Standard / 1/10 speed (10 : 1)	Standard / 1/2 speed (2 : 1)	Half / 1/10 speed (5 : 1)	Half / 1/20 speed (10 : 1)	Standard ×1.5 / 0.75 speed (2 : 1)	Standard ×2 / standard speed (2 : 1)
1/2	13	6.5	—	—	—	13/1.3	13/6.5	6.5/1.3	6.5/0.65	—	—
1	13	6.5	3.3	20	26.5	13/1.3	13/6.5	6.5/1.3	6.5/0.65	20/10	26.5/13.2
2	10	5.0	2.5	13	18	10/1.0	10/5.0	5.0/1.0	5.0/0.50	13/6.5	18/9.0
3	9.0	4.5	2.3	13	18	9/0.90	9/4.5	4.5/0.9	4.5/0.45	13/6.5	18/9.0
5	8.0	4.0	2.0	—	12	8/0.80	8.0/4.0	4.0/0.80	4.0/0.40	—	12/6.0
7.5	7.2	3.6	1.8	—	12	7.2/0.72	7.2/3.6	3.6/0.72	3.6/0.36	—	—
10	6.0	3.0	1.5	8.8	—	6.0/0.60	6.0/3.0	3.0/0.60	3.0/0.30	—	—
15	6.0	3.0	1.5	—	—	6.0/0.60	6.0/3.0	3.0/0.60	3.0/0.30	—	—
20	5.0	2.5	1.2	—	—	5.0/0.50	5.0/2.5	2.5/0.50	2.5/0.25	—	—
30	3.3	1.7	—	—	—	3.3/0.33	3.3/1.7	1.7/0.33	1.7/0.17	—	—

NOTE : 1: * Indicates two-step operation.

Specifications Table

60Hz

(Unit: m/min)

Rated load (t)	Standard speed	Low-speed traversing		High-speed traversing	* Dual-speed traversing		
		Slow	Creep (1/4 speed)		Standard / 1/4 speed (4 : 1)	Standard / half speed (2 : 1)	Standard ×2 / standard speed (2 : 1)
1/2	25	12.5	6.0	—	25/6.0	25/12.5	50/25
1	25	12.5	6.0	—	25/6.0	25/12.5	50/25
2	25	12.5	6.0	—	25/6.0	25/12.5	50/25
3	25	12.5	6.0	—	25/6.0	25/12.5	50/25
5	25	12.5	6.0	—	25/6.0	25/12.5	50/25
*7.5	17	12.5 8.5	4.2	25	17/4.2	25/12.5 17/8.5	—
*10	17	12.5 8.5	4.2	25	17/4.2	25/12.5 17/8.5	—
15	17	8.5	4.2	—	17/4.2	17/8.5	—
20	17	8.5	4.2	—	17/4.2	17/8.5	—
*30	17	8.5	4.2	—	17/4.2	17/8.5	—

NOTE : 1: * 7.5, 10 (tons): The upper stage is of the standard type, and the lower stage is of the double rail type.
* 30 (tons): Available only for the double rail type.

Special Specifications Hoist

Explosion-proof Type Hoist

The hoist is designed to have a specific structure available for use where there is a danger of gas explosion.

Specifications

Standard	Type	Rated load (t)	Lift (m)
Ignition group: G ₄ Explosion proof: 2	Standard	1,2,3,5	6,12,24,36 (1–3t) 8,12,24,36 (5t)
	Low head	1,2,3,5	6,12
	Double rail	2,3,5	12 (2t) 6,12 (3t) 8,12 (5t)

NOTE : The explosion-proof specifications are also available for rated loads of 1/2, 2.8, 7.5 and 10 (tons) upon request.

For more details, see the Hitachi Explosion-Proof Type Hoists catalogue.

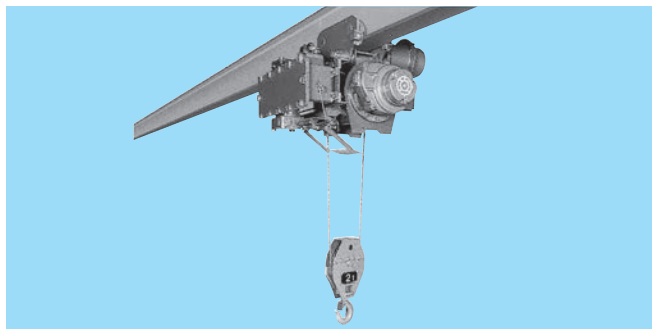

Multi Hook Type Hoist

The hoist has two or four hooks suitable for lifting bars, plates, automobile bodies, and furniture which has a large volume compared with its weight, and which may swing or slant during hoisting.

Twin Hook Type Hoist

Rated load (t)	Lift (m)	Hooking pitch (m)
1–5	6	0.8–1.0

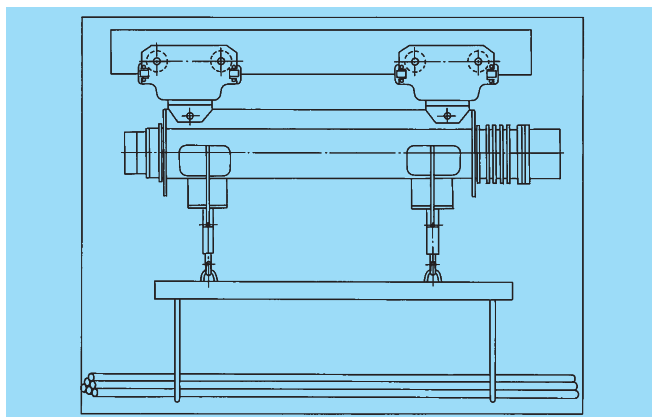

Four Hook Type Hoist

One-drum types, which contain four separate wire ropes, and two-drum types are available (special order products).

Hoist with Upper and Lower Limit Switches

Hoists with upper and lower limit switches (UDS-V₅) are suitable for repeated operation with specified upper and lower load block stop positions.

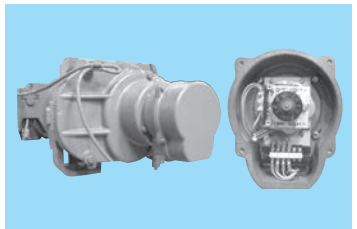

NOTE : The limit switches alone cannot be ordered. They are to be mounted on the body of the hoist. Unless otherwise specified, the upper limit is adjusted to 150mm below the operating point of the upper limit switch, and the lower limit is adjusted on site according to the lifting requirement.

UDS-V₅ Specifications

Contact structure	(Ia, Ib) × 2
Contact capacity	250V, 4A
Upper limit position	Within the lifting distance under the limit lever
Lower limit position	Within the lifting distance from two additional windings of the drum

UDS-V₅ Operation

The VDS-V₅ takes the revolution of the lifting motor taken out from the end bracket in the gear case, and feeds it to the reduction gear inside the UDS-V₅, which turns the cam in order to open and close the limit switch.

Hoist with Load Limiter

The hoist is equipped with an overload prevention device, which detects the lifting motor current and stops lifting when the load is too heavy. It is suitable for preventing dangerous work.

Specification Table

Specifications		D type load limiter		
		LL-4D	LL-70D	LL-100D
Applicable models	200V class	—	A-series 1–3t V-series 1/2–10t	V-series Over 15t
	400V class	A-series 1t V-series 1/2t	A-series 2–3t V-series 1–30t	—
Electric source		200V 50/60Hz, 220V 60Hz		
Voltage fluctuation		Rated voltage ±10%		
Ambient temperature		–10°C–40°C (without freeze)		
Approx. weight		3.5kg		
Other		Reset: Return to down position / Time: 0.3 sec or less		

Notes on use

- A dustproof case or anti-corrosion enclosure is required when the hoist is used in a dusty place (e.g. foundry) or a place where corrosive gases are present (e.g. a plating factory, or a factory adjacent to the seaside). If this is the case, please make a separate inquiry.
- Avoid rain when using the hoist in the open air.
- The 400V class power source can be used for the hoist motor, but needs to be adjusted to the voltages specified for use in the above table, for example, a transformer for the supply to the operation circuits and the load limiter.

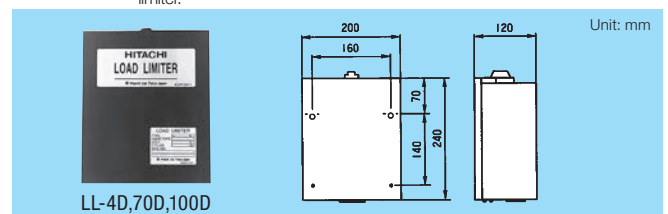

End Carriage

Fully applying Hitachi's modern mechanical engineering technology, Hitachi End Carriage are designed to withstand full load under severe operating conditions. Excelling in performance, reliability, and durability, Hitachi End Carriage will definitely improve your crane's mobility, thus contributing to rationalizing your loading / unloading operations.

These three types of Hitachi End Carriage are available :

1. Toprun type

This on-rail-type End Carriage with a wide application range is extensively used for hoist cranes.

2. Suspension type

The suspension type End Carriage can be placed under existing roof beams.

Adopting a shaped-steel frame, the suspension-type End Carriage is used in combination with the standard rope hoist or the electric chain hoist.

3. Wheel unit for toprun-type End Carriage

With the driving side and the driven side of the wheel unit forming a pair, it is optionally sold for use with a crab or a traverser.

● Toprun Type (Double channel structure)

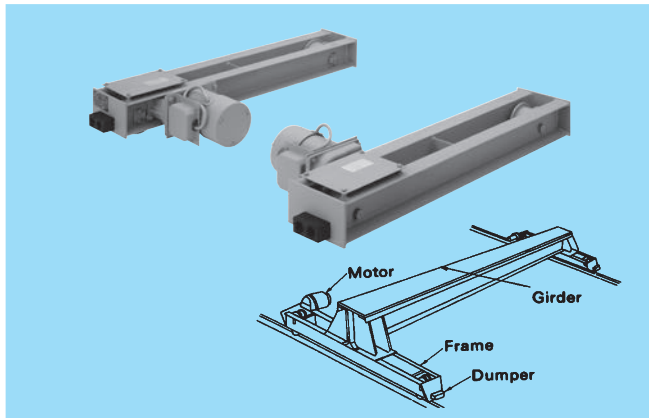

■ Applicable Range

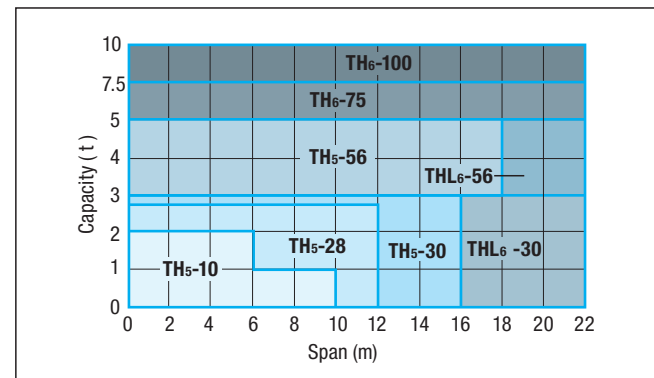

■ Specifications table

Model	TH5-10	TH5-28	TH5-30	THL6-30	TH5-56	THL6-56	THL6-75	THL6-100
Specifications								
Max. wheel load (t)	1.0	2.8	3.0	3.0	5.6(4.0)*	5.6(4.0)*	7.5(5.0)*	10.0(5.6)
Traveling speed (50/60 Hz)(m/min.)	21/25	21/25	21/25	21/25	21/25	21/25	21/25	25/30
Motor (with brake) (50/60 Hz)(kW)	0.30/ 0.36 ×2	0.30/ 0.36 ×2	0.30/ 0.36 ×2	0.30/ 0.36 ×2	0.70/ 0.84 ×2	0.70/ 0.84 ×2	0.70/ 0.84 ×2	1.5/ 1.8 ×2
Rating	25% ED 250 Starts/h							
Wheel Dia. (mm)	125	180	180	180	250	250	300	355
Wheel tread width (mm)	56	63	63	63	70	70	80	80
Traveling rail (kg)	12,15	15,22	15,22	15,22	22,30	22,30	30,37	30,37
Approx. weight (kg)	70×2	110×2	175×2	200×2	250×2	305×2	435×2	650×2
Electric source (3 phase)	200V 50/60Hz, 220V 60Hz, 380-400V 50Hz, 415V 50Hz, 440-460V 60Hz							

*Figure shown in () is applied for a monorail girder.

■ Table of Dimensions

Model	TH5-10	TH5-28	TH5-30	THL6-30	TH5-56	THL6-56	TL6-75
Frame size(mm)	125×65×6	150×75×6.5	180×75×7	180×75×7	200×80×7.5	200×90×8	250×90×9
Approx. dimensions (mm)	φA	178	229	229	299.6	300	359
	φB	155	210	210	210	282	340
	C	27.5	20	15	15	5	—
	φD	125	180	180	180	250	300
	E ₁	109	135	135	135	145	155
	E ₂	126	160	160	160	177	187
	F	447	473	473	473	515	516
	G	120	150	300	164	350	214
	H	20	30	30	30	40	40
	J	12	19	22	22	30	30
	K	141	169	196	196	220	220
	L	22	34	22	23	47	41

Model	TH5-10	TH5-28	TH5-30	THL6-30	TH5-56	THL6-56	TH6-75
Frame size(mm)	125×65×6	150×75×6.5	180×75×7	180×75×7	200×80×7.5	200×90×8	250×90×9
Approx. dimensions (mm)	M	245	311	295	295	322	360
	N	120	150	135	135	175	210
	P	158.6	201	201	201	235	263
	Q	1,340	1,800	2,535	3,049	2,965	3,386
	R	1,000	1,400	2,000	2,650	2,300	2,800
	S	105	145	145	145	162	180
	T	56	63	63	63	70	80
	U	25	35	35	35	60	60
	V	50	50	50	50	60	60
	W	50	50	50	50	70	70
	X	155	165	165	165	165	200

End Carriage

TH5-10/TH5-28/THL6-30/THL6-56/TH6-75

Unit : mm

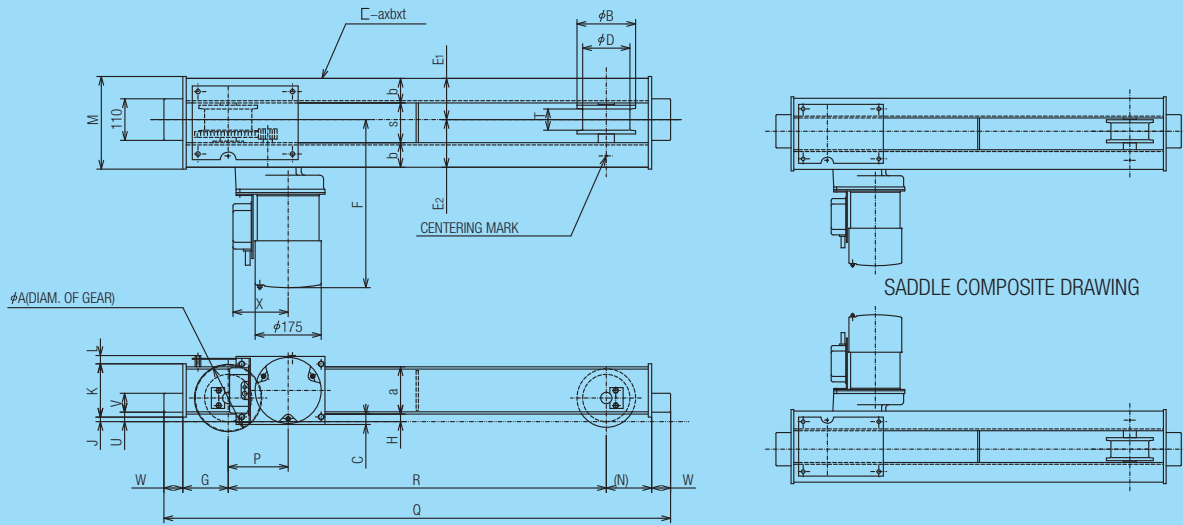

TH5-30/TH5-56

Unit : mm

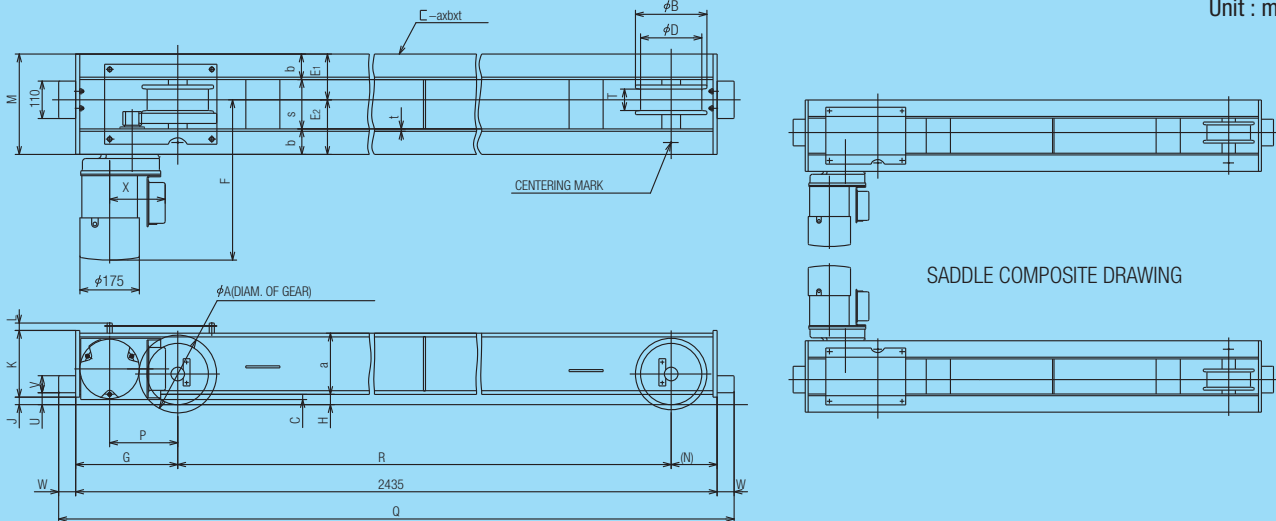

TH6-100

Unit : mm

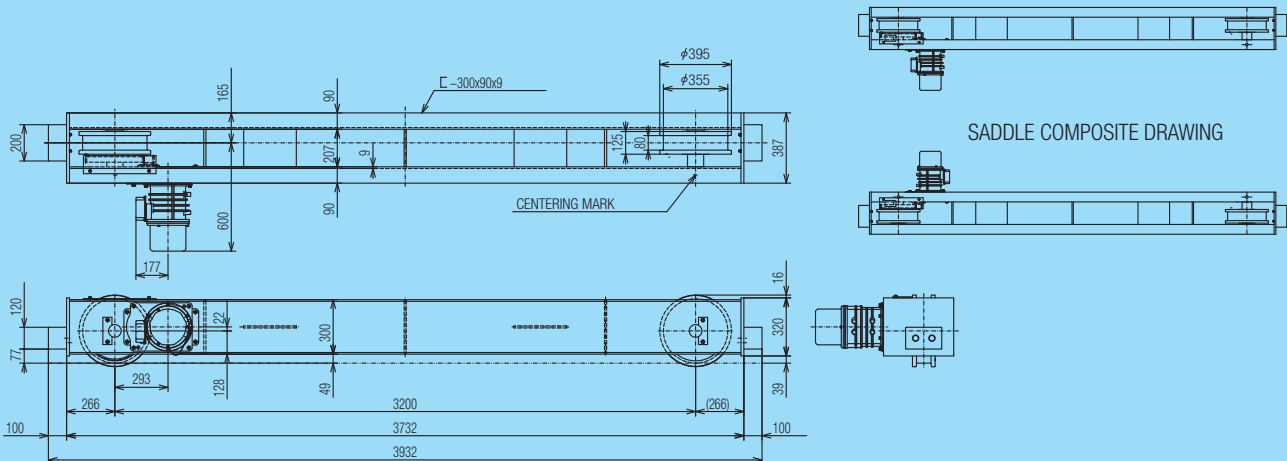

End Carriage

Suspension Type

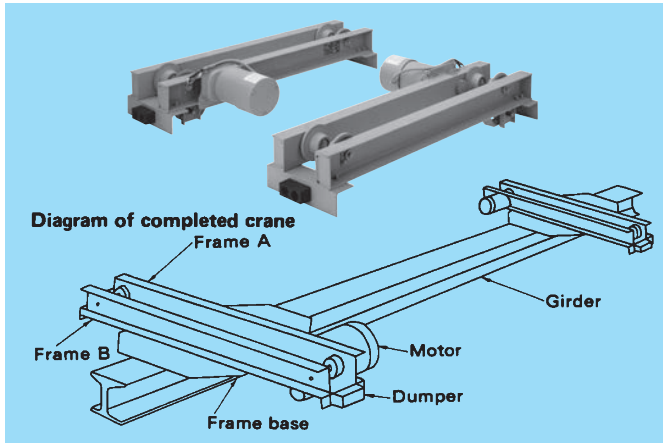

Dimensions

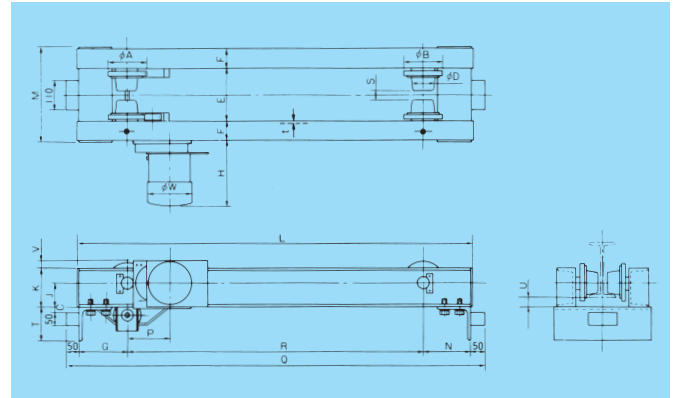

Specifications

Model	SL5-10	SL6-28	SL5-30	SL5-56
Max. wheel load (t)	1.0	2.8	3.0	5.6
Traveling speed (50/60Hz)(m/min.)	21/25			
Motor (with brake) (50/60Hz)(kW)	0.30/0.36×2		0.70/0.84×2	
Rating	25% ED 250 Starts/h			
Approx. weight (kg)	70×2	105×2	140×2	224×2
Electric source (3 phase)	200V 50/60Hz, 220V 60Hz, 380-400V 50Hz, 415V 50Hz, 440-460V 60Hz			

Applicable Range

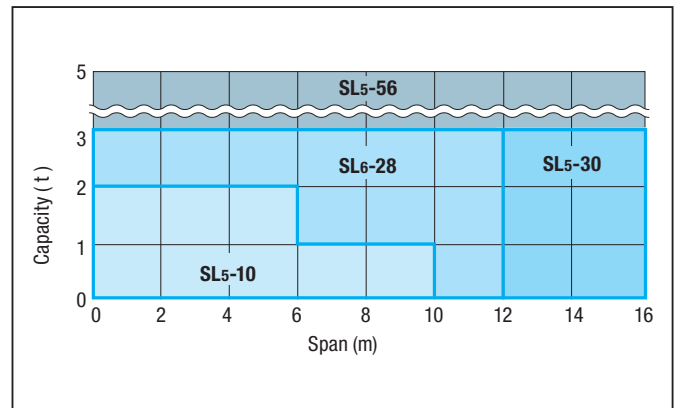

Table of Dimensions

Model	SL5-10	SL6-28	SL5-30	SL5-56								
Frame size (mm)	125×65×6	150×75×6.5	180×75×7	250×90×9								
Approx. dimensions (mm)	φ A	144	163	163	222.3							
	φ B	144	163	163	222.3							
	C	15	20	20	20							
	φ D	76	100	100	140							
	F	65	75	75	90							
	G	147	158	158	158							
	H	294	294	294	309							
	J	73	85	90	120							
	K	125	150	180	250							
	L	1,300	1,720	2,320	2,320							
	M	350	397	397	422(397)							
	N	147	158	158	158							
	P	153.4	158.3	158	188.4							
	Q	1,394	1,816	2,416	2,416							
	R	1,000	1,400	2,000	2,000							
T	90	100	100	100								
V	36	31	10	—								
φ W	175	175	175	175								
Dimensions (mm)												
I-Beam (mm)	E	S	U	E	S	U	E	S	U	E	S	U
200×100×7	158	37	25									
250×125×7.5	183	62	22	193	49	23	192	49	28			
300×150×11.5	208	87	13	217	74	15	217	74	20	217	67	30
450×175×11				243	99	18	242	99	23	242	92	33

Unless otherwise specified trolley is being assembled so as to meet smudged I-beam size.

End Carriage with Creep Speed

- Electric source / 200V 50/60Hz, 220V 60Hz, 380—400V 50Hz, 415V 50Hz, 440—460V 60Hz
- Rating / 30 min (based on JIS C9620)
- Starting frequency and duty factor / 250 starts/h, 25% ED
- Protective structure / Dustproof type, indoor specifications

Standard Specification Table

Model		Top run type						Suspension type			
		TH type						SL type			
Type		THC ₅ -10	THC ₅ -28	THC ₅ -30	THLC ₆ -30	THC ₅ -56	THLC ₆ -56	SLC ₅ -10	SLC ₅ -28	SLC ₅ -30	SLC ₅ -56
Max. wheel load (t)		1	2.8	3		5.6*(4)		1	2.8	3	5.6
Max. span (m)		10	12	16	20	18	20	10	12	16	16
Travelling speed (m/min) Standard / creep	50Hz	21/5						21/5			
	60Hz	25/6						25/6			
Motor	kW	0.30/0.08×2				0.70/0.18×2		0.30/0.08×2		0.70/0.18×2	
	Standard / creep	0.36/0.09×2				0.84/0.21×2		0.36/0.09×2		0.84/0.21×2	
No. of poles, standard / creep		2/8						2/8			
Rating		25% ED, 250 starts/h						25% ED, 250 starts/h			
Wheel diameter (mm)		φ125	φ180		φ250		φ76	φ100		φ140	
Wheel material		FCD heat treatment						S45C heat treatment			
Applicable rail		12, 15kg	15, 22kg			22, 30kg		200×100×7 250×125×7.5 300×150×11.5	200×100×7 250×125×7.5 300×150×11.5 450×175×11	300×150×11.5 450×175×11	
Approx. weight (kg)		80×2	120×2	185×2	200×2	260×2	320×2	80×2	115×2	150×2	224×2

NOTES : 1 : Only anti-corrosion coating is applied on the body.
 2 : THC₅-56, THLC₆-56 and THMC₅-45 are for the double rail hoist.
 3 : (4) indicates the maximum wheel load for the monorail girder.

Toprun Type

Applicable Range

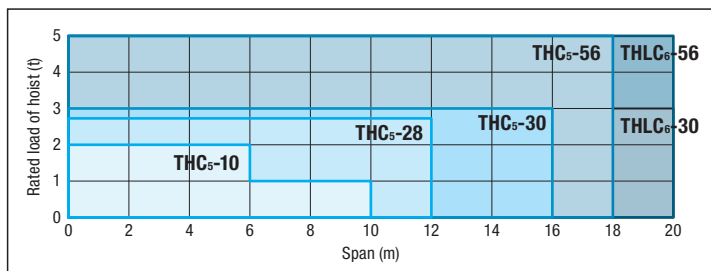

NOTE : 1. The above drawing shows an outline of the model selection.
 In practice, wheel load calculation including the girder is required.

Suspension Type

Applicable Range

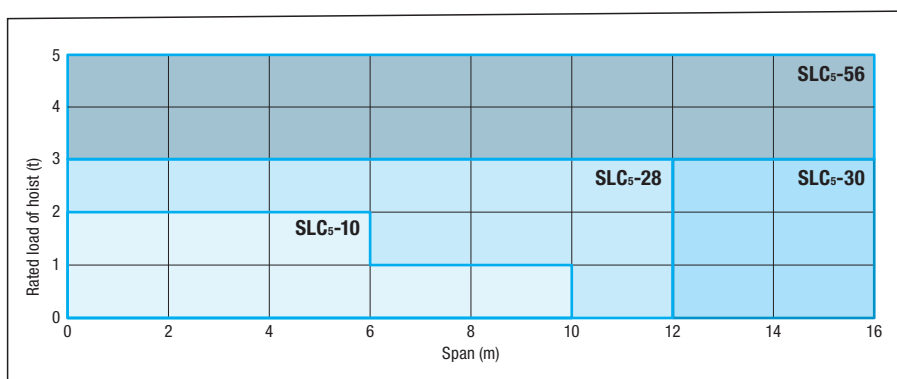

NOTE : 1. The above drawing shows an outline of the model selection. In practice, wheel load calculation including the girder is required.

Wheel Unit for Toprun Type End Carriage

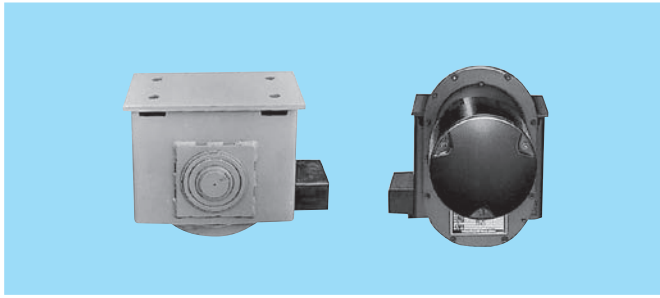

Specifications

Model	TLU5-28	TLU5-56
Max. wheel load (t)	2.8	5.6
Traveling speed (50/60Hz)(m/min.)	21/25	21/25
Motor (with brake) (50/60Hz)(kW)	0.30/0.36	0.70/0.84
Rating	25% ED 250 Starts/h	
Electric source (3 phase)	200V 50/60Hz, 220V 60Hz, 380-400V 50Hz, 415V 50Hz, 440-460V 60Hz	
Rail (kg)	22	30

Dimensions

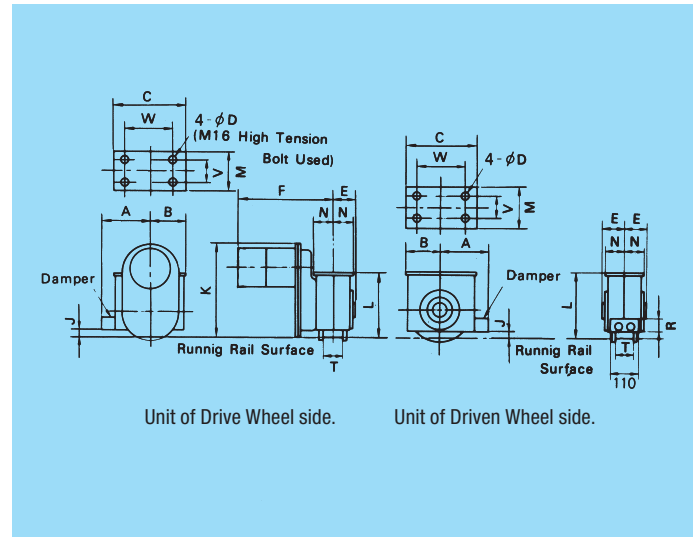

Applicable Range

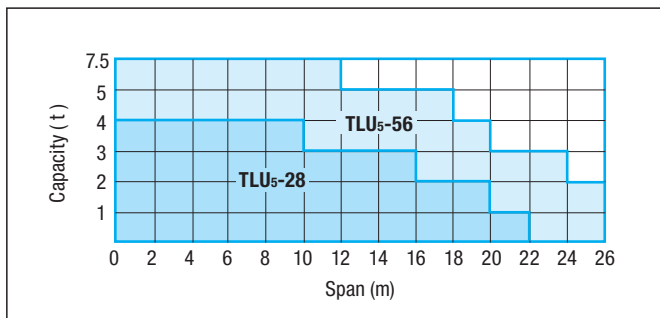
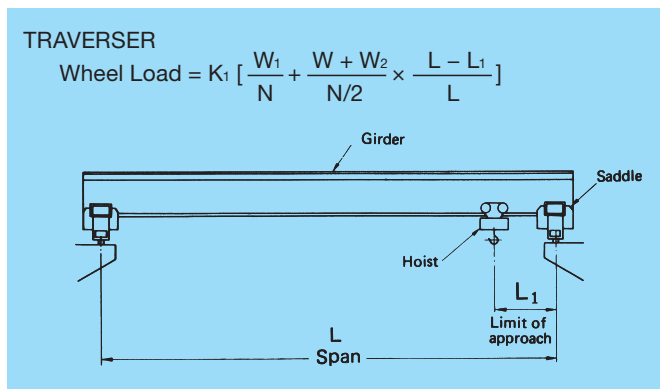

Table of Dimensions

Type		TLU5-28	TLU5-56
Approx. dimensions (mm)	A	180	230
	B	135	170
	C	270	340
	φ D	18	22
	E	81	95
	F	410	450
	J	25	45
	K	352	372
	L	240	290
	M	140	190
	N	70	95
	R	50	60
	V	80	100
W	190	230	
Approx.weight	(kg)	65	125
Wheel tread (mm)	T	63	70

Wheel Load Calculation for Traversers and Crabs



N : Number of Crane Wheels=4 W₁ : Weight of Crane (t)
 W : Rated Load (t) W₂ : Weight of Hoist (t)

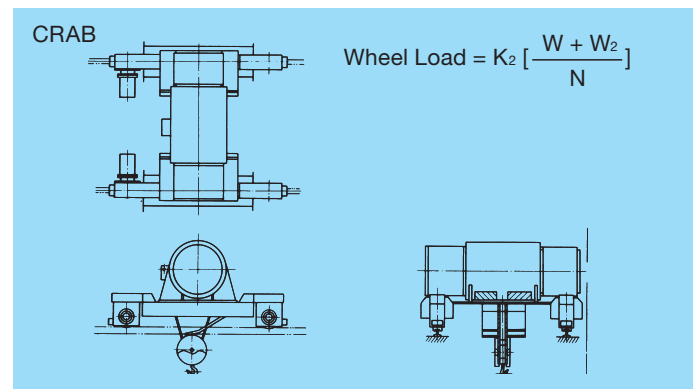

L : Span (m) K₁ : Impact Coefficient (1.2)
 L₁ : Limit of Approach (m) K₂ : Impact Coefficient (1.6)

Specifications are subject to change without notice.

Wheel Unit for Gantry End Carriage

- The wheel unit for Hitachi's gantry End Carriage is a compact unit with integrated structure.
- It can be used not only for gantry cranes but also for traversing equipment of overhead traveling cranes.

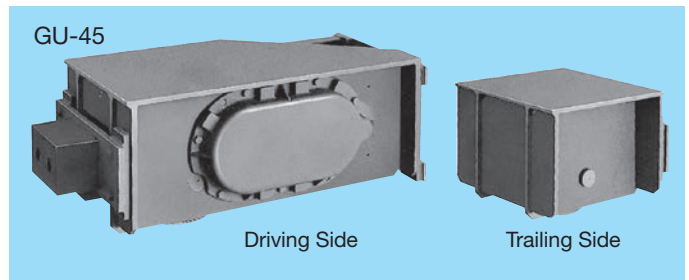

Standard Specifications

Model	GU-45	GU5-56	GU5-75
Max. Wheel Load	4.5	5.6	7.5
Traveling Speed (50/60Hz)(m/min.)	25 / 30	30 / 36	
Motor (50/60Hz) (kW)	1.2/1.5 (With brake)	2.5/2.9 (With brake)	
Motor Pole Number	4		
Rating	25% ED 250 Starts / h		
Electric Source (3 phase)	200V 50/60Hz, 220V 60Hz, 380-400V 50Hz, 415V 50Hz, 440-460V 60Hz		
Brake Torque (TB/TM)	0 - 60 %		
Traveling Rail (kg)	22 , 30	22 , 30	30 , 37
Approx Weight (kg)	340	260	360

*The coating of the main body consists of only the rust proof coating.

Applicable Range

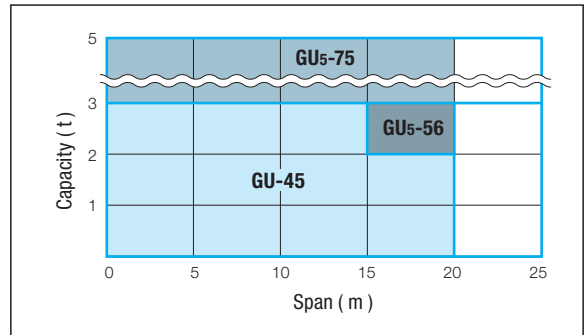

* If the span exceeds 20m there is danger of the motor lacking output by the influence of the wind. Therefore, the maximum span is limited to 20m.

Dimensions

GU-45

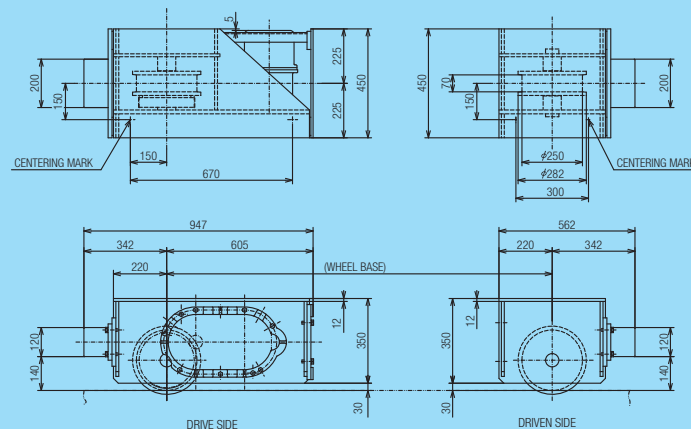

GU5-56/GU5-75

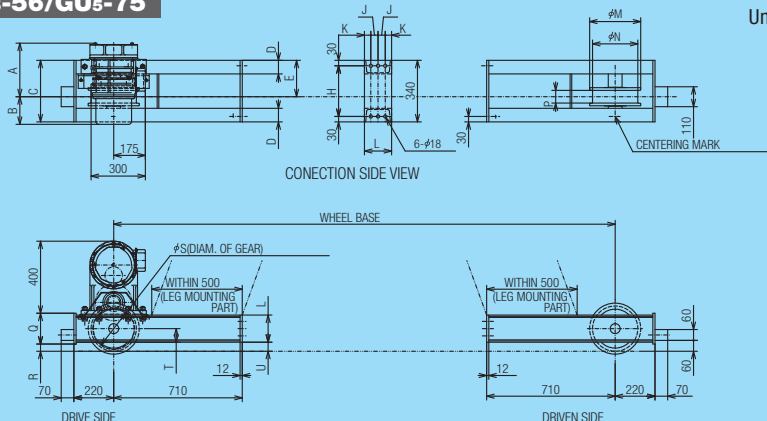

Type	GU5-56	GU5-75
A	295	310
B	155	145
C	340	370
D	75	80
E	201	217
H	280	310
J	40	50
K	35	50
L	150	200
φM	282	340
φN	250	300
P	70	80
Q	170	220
R	40	37
φS	230.3	275.3
T	75	102
U	50	47

Approx. dimensions (mm)

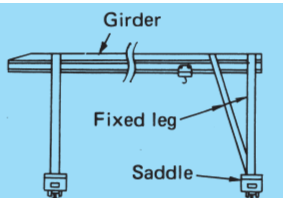

K_1 : Impact Coefficient (1.2)

W_2 : Weight of Hoist (t)

W_3 : Weight of Girder (t)

W_4 : Weight of End Carriage (t)

W_5 : Weight of Fixed Leg (t)

W : Rated Load (t)

$$\text{Wheel Load} = K_1 \left(\frac{W_3 + W_4}{4} + \frac{W_5 + W + W_2}{2} \right)$$

For Installing the Hitachi Hoist

Size of I-Beam and Max. Allowable Span

Standard I-beam sizes and marked with ○.

Hitachi hoists are supplied, based on the I-beam size marked with ●, unless otherwise specified.

Capacity (t)	Max. allowable I-beam span (m)								
	Dimensions of I-beam employed (mm)								
	150×75×5.5	200×100×7	250×125×7.5	250×125×10	300×150×11.5	350×150×12	400×150×12.5	450×175×11	600×190×13
1/2	○3.0	●4.5	○7.0	○7.9					
1		○3.5	●5.4	○6.4	○8.6	○9.9			
2		○2.3	●4.0	○4.9	○6.9	○8.0	○8.5		
3			○2.9	○3.8	●5.6	○6.4	○7.1	○8.0	
5					●4.1	○4.9	○5.6	○6.2	
7.5								●4.5	○7.1
10								●3.9	○6.1
15								●3.1	○4.9
20								●2.7	○4.3

NOTES : 1.Values shown in above list are applied for a telfer.

2.Max. allowable I-beam span is decided by capacity of a hoist , without affected by type of a hoist or a trolley.

Traveling Rail Stopper

This is a simple construction where two angle steels are installed on both sides of the I-beam. Rubber should be applied to the stopper surfaces to soften shocks when the hoist strikes the stopper surfaces.

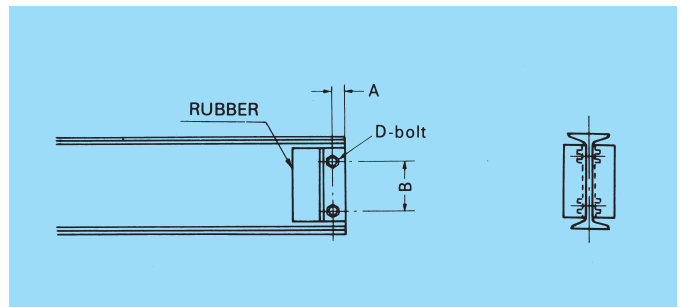

I-beam (mm)	150×75	200×100	250×125	350×150	450×175
Angle steel (mm)	50×50×6			65×65×6	
A (mm)	22			30	
B (mm)	70	105	110	190	280
D (mm)	M10	M16	M16	M20	M20

For Installing the Hitachi Hoist

Stopper For Double-Rail Type Hoist

Set the stoppers on traveling rails so that both side of the wheel contacts the stoppers simultaneously. The dimension “a” must cover more than half of the wheel diameter.

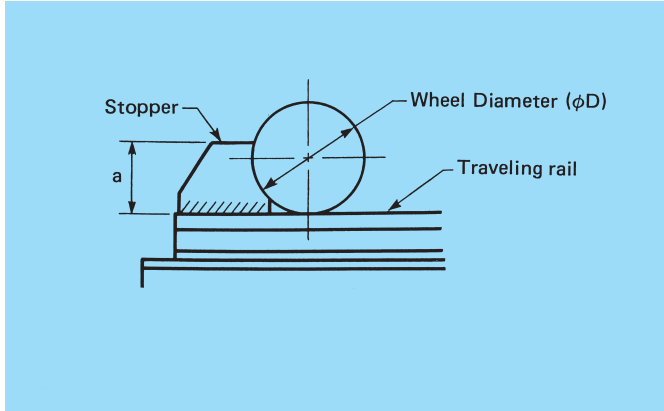

Capacity (t)	Wheel diameter (φD)	a (mm)
2,3,5	160	40
7,5,10	195	50
15,20	250	65
30	350	90

The self-adjusting center core, as shown in the figure below, is adopted on the driven side so that the four wheels correctly contact the rail. Therefore, height difference between the rails causes eccentric of the axle as illustrated below . In consideration of this eccentric amount, place the stoppers so that both side of the wheel contacts the stoppers simultaneously.

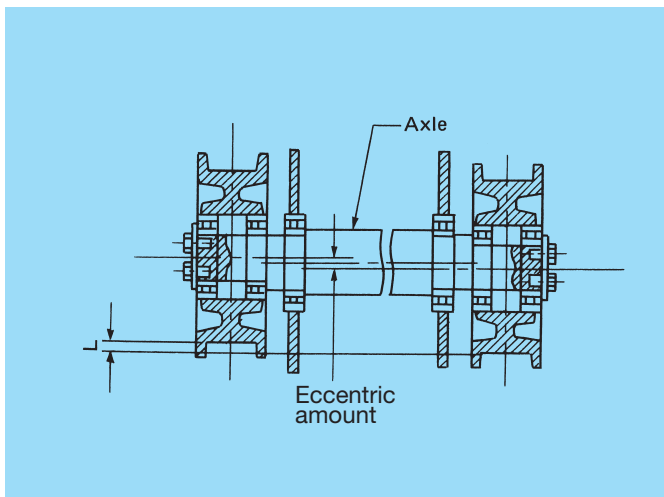

Capacity (t)	Max.L (mm)
2, 3, 5	10
7, 5, 10	15
15, 20	15
30	15

For Installing The Hitachi Hoist

Power cable allowable length

The power cable allowable length for the standard specification is shown in the following table.

When extending the power cable or relay cable, make a selection after referring to the following table.

A-series

Power Source	Capacity (t)	Permissible Length of Power Source Cable (m)						Minimum Fuse Capacity (A)
		Nominal Sectional Area of Conductor (mm ²)						
		0.75	1.25	2	3.5	5.5	8	
220V 50Hz	1	24	40	64	112	—	—	15
	2	—	—	38	66	103	—	20
	3	—	—	—	42	65	94	40
380-415V 50 Hz	1	67	111	177	309	—	—	10
	2	—	67	107	187	293	—	15
	3	—	41	65	113	177	257	30

V-series (200V class)

Capacity (t)	Hoist Motor (kW)	Power Source	Permissible Length of Power Source Cable (m)														
			Nominal Sectional Area of Conductor (mm ²)														
			0.75	1.25	2	3.5	5.5	8	14	22	30	38	60	80	100	125	
1/2	1.0	200V 50Hz	28	47	76	133	209										
	1.2	200V 60Hz	13	23	37	65	102										
1	1.9	200V 50Hz	—	25	40	71	112	163	285								
	2.3	200V 60Hz	—	12	20	35	55	80	140								
2	2.9	200V 50Hz	—	—	<22>	38	59	86	151	237							
	3.5	200V 60Hz	—	—	<10>	18	28	41	72	113							
(2.8) 3	4.2(4.0)	200V 50Hz	—	—	—	<31>	48	70	123	193							
	5(4.8)	200V 60Hz	—	—	—	<15>	23	34	60	94							
5	5.9	200V 50Hz	—	—	—	—	—	48	84	132	180	228					
	7	200V 60Hz	—	—	—	—	—	23	40	63	86	109					
7.5	7.9	200V 50Hz	—	—	—	—	—	—	24	37	51	65	103	138			
	9.5	200V 60Hz	—	—	—	—	—	—	27	42	58	73	116	155			
10	8.8	200V 50Hz	—	—	—	—	—	—	24	37	51	65	103	138			
	10.5	200V 60Hz	—	—	—	—	—	—	27	42	58	73	116	155			
15	6.7×2	200V 50Hz	—	—	—	—	—	—	25	34	43	68	91	113	142		
	8×2	200V 60Hz	—	—	—	—	—	—	28.5	39	49	78	103	129	162		
20	7.5×2	200V 50Hz	—	—	—	—	—	—	21	28	36	56	74	173	136		
	9×2	200V 60Hz	—	—	—	—	—	—	23	32	40	63	84	105	132		
30	7.5×2	200V 50Hz	—	—	—	—	—	—	21	28	36	56	74	173	136		
	9×2	200V 60Hz	—	—	—	—	—	—	23	32	40	63	84	105	132		

V-series (400V class)

Capacity (t)	Hoist Motor (kW)	Power Source	Permissible Length of Power Source Cable (m)														
			Nominal Sectional Area of Conductor (mm ²)														
			0.75	1.25	2	3.5	5.5	8	14	22	30	38	60	80	100	125	
1/2	1.0	380-415V 50Hz	54	90	144	252											
	1.2	400V 60Hz	26	46	74	130											
1	1.9	380-415V 50Hz	—	48	76	133	209										
	2.3	400V 60Hz	—	24	40	70	110										
2	2.9	380-415V 50Hz	—	—	41	72	113	165									
	3.5	400V 60Hz	—	—	36	56	82	144									
(2.8) 3	4.2(4.0)	380-415V 50Hz	—	—	33	58	91	132									
	5(4.8)	400V 60Hz	—	—	—	46	68	120									
5	5.9	380-415V 50Hz	—	—	—	40	62	91	159								
	7	400V 60Hz	—	—	—	—	31	46	80	126							
7.5	7.9	380-415V 50Hz	—	—	—	—	—	—	45	71	97	123					
	9.5	400V 60Hz	—	—	—	—	—	—	54	84	116	146					
10	8.8	380-415V 50Hz	—	—	—	—	—	—	45	71	97	123					
	10.5	400V 60Hz	—	—	—	—	—	—	54	84	116	146					
15	6.7×2	380-415V 50Hz	—	—	—	—	—	—	47	64	82	129					
	8×2	400V 60Hz	—	—	—	—	—	—	57	78	98	156					
20	7.5×2	380-415V 50Hz	—	—	—	—	—	—	54	72	92	146					
	9×2	400V 60Hz	—	—	—	—	—	—	40	54	63	108					
30	7.5×2	380-415V 50Hz	—	—	—	—	—	—	40	54	63	108					
	9×2	400V 60Hz	—	—	—	—	—	—	46	64	80	126					

Standards and Applied Class to the Hitachi Hoists

Code in Each Standard	Structural Code for Cranes (Japan)	A	B	C	D	E	F	
	JIS C 9620	M3	M4	M5	M6	M7	M8	
	JIS B 8822-1							
	FEM 9.511	1Bm	1Am	2m	3m	4m	5m	
(1) Total Operating Time (Lifetime at full load h)		$h \leq 400$	$400 < h \leq 800$	$800 < h \leq 1600$	$1600 < h \leq 3200$	$3200 < h \leq 6300$	$6300 < h \leq 12500$	
Hitachi' s Specification	V-series Hoists					●		
	A-series Hoists					●		
Load Condition	Load Ratio	Mean operating hour per day						
Light	$K \leq 0.5$	≤ 2	≤ 4	≤ 8	≤ 16	≥ 16	—	
Medium	$0.5 < K \leq 0.63$	≤ 1	≤ 2	≤ 4	≤ 8	≤ 16	≥ 16	
Heavy	$0.63 < K \leq 0.8$	≤ 0.5	≤ 1	≤ 2	≤ 4	≤ 8	≤ 16	
Severe	$0.8 < K \leq 1$	≤ 0.25	≤ 0.5	≤ 1	≤ 2	≤ 4	≤ 8	
(2) Repetitive Rating	Duty (% ED)	25	30	40	50	60	60	
	Max. Starting Frequency	150	180	240	300	360	360	
Hitachi' s Specification	V-series Hoists			○	●	40% ED, 400 Starts/h		
	A-series Hoists		○	●	25% ED, 250 Starts/h			
(3) Ratio of Wire Rope Dia. (d) to Sheave (D)	FEM	Drum	14	16	18	20	22.4	25
		Sheave	16	18	20	22.4	25	28
		Equalizer sheave	12.5	14	14	16	16	18
	JIS Structural Code for Cranes	Drum	14	16	18	22.4	28	35.5
		Sheave	16	18	20	25	31.5	40
		Equalizer sheave	10	10	10	10	12.5	14
Hitachi' s Specification	V-series Hoists	Applicable to JIS (NA to FEM)						
	A-series Hoists	Applicable to JIS (NA to FEM)						

Applied Class to FEM standard

(1) V-Series WR Hoists	Between 2m and 3m
(2) A-Series WR Hoists	Between 1Am and 2m

* Total operating time, repetitive rating are considered for the classification.

Ratio of the wirerope diameter to the sheave one, so called D/d, is exempted from the judgment, because the idea for the safety is different and the values are greatly different between JIS and FEM standard.

Network

Hitachi Industrial Equipment Systems Co., Ltd. meets customers' needs through the total network which can supply speedy design, production, sales, service and engineering for industrial equipment and systems.

Global Sales Network



Asia & Oceania

China

Hitachi Industrial Equipment Systems (China) Co., Ltd.
(Shanghai Office)
Room2201, Rui Jin Building, No.205
Maoming Road(S) Shanghai 200020
TEL : +86 (21) 5489-2378
FAX : +86 (21) 3356-5070

(Beijing Office)

Room1420, Beijing Fortune Building,
No.5 Dong San Huan Bei Road,
Chao Yang District, Beijing 100004
TEL : +86 (10) 6590-8180
FAX : +86 (10) 6590-8189

(Guangzhou Office)

Room3003, HNA Tower,
8# Linhezhong Road, Tianhe District,
Guangzhou 510610
TEL : +86 (20) 3877-3819
FAX : +86 (20) 2735-3820

Hitachi Industrial Equipment Systems (Hong Kong) Co., Ltd.

8/F, Building 20E, Phase 3, Hong Kong
Science Park, Pak Shek Kok,
New Territories, Hong Kong
TEL : +852 2735-9218
FAX : +852 2735-6793

Taiwan Hitachi Asia Pacific Co., Ltd
3rd Floor, No. 167, Tun Hwa N. Road,
Hung-Kuo Building, Taipei 105, Taiwan
TEL : +886 (2) 2718-3666
FAX : +886 (2) 2514-7664

India

Hitachi India Private Limited
Ground & First Floor, Tower B, World
Mark 1,
Asset Number 11, Aerocity, NH-8, New
Delhi-110037
TEL : +91 (11) 4060-5252
FAX : +91 (11) 4060-5253

Indonesia

PT Hitachi Asia Indonesia
Menara BCA 38th Floor Suite #3804 &
3805 Jl. M. H Thamrin No.1, Jakarta
10310, Indonesia
TEL : +62 (21) 2358-6757
FAX : +62 (21) 2358-6755

Malaysia

Hitachi Industrial Equipment (Malaysia)
Sdn. Bhd.
Lot 6498, Batu 5 3/4 , Lorong Haji Abdul
Manan, 42100 Klang, Selangor,
Malaysia
TEL : +60 3 3290 2323
FAX : +60 3 3290 7570

Philippines

Hitachi Asia Ltd. (Philippines Branch)
Unit 8, 11th Floor Zuellig Bldg., Makati
Avenue corner Paseo de Roxas,
Makati City, Philippines 1225
TEL : +63 (2) 886-9018
FAX : +63 (2) 887-3794

Singapore

Hitachi Asia Ltd.
(Industrial Components & Equipment
Group)
No.30, Pioneer Crescent
#10-15, West Park Bizcentral
Singapore 628560
TEL : +65-6305-7400
FAX : +65-6305-7401

Thailand

Hitachi Asia (Thailand) Co., Ltd.
12th Floor, Ramaland Bldg., No.952
Rama IV Road, Suriyawong Bangrak,
Bangkok 10500, Thailand
TEL : +66 2 632 9292
FAX : +66 2 632 9299

Viet Nam

Hitachi Asia (Viet Nam) Co., Ltd.
(Ho Chi Minh City Office)
R. 8-9-10A, 4th FL., The Landmark
Bldg, 5B Ton Duc Thang, Dist. 1, Ho
Chi Minh City, Vietnam
TEL : +84 28 3829 9725
FAX : +84 28 3829 9729

(Ha Noi Office)

23th Floor, Lotte Center Hanoi, 54 Lieu
Giai St., Cong Vi Ward, Ba Dinh Dist.,
Hanoi, Vietnam
TEL : +84 24 3933 3123
FAX : +84 24 3933 3125

Australia

Hitachi Australia Pty Ltd.
Suite 801, Level 8, 123 Epping Road
North Ryde NSW 2113, Australia
TEL : +61 2 9888 4100
FAX : +61 2 9888 4931

Europe

Germany

Hitachi Europe GmbH
Niederkaßeler Lohweg 191, 40547
Düsseldorf, Germany
Tel: +49 (211) 5283 0
FAX: +49 (211) 5283 649

Latin America

Mexico

Hitachi Industrial Equipment Mexico,
S.A. de C.V.
Paseo de la Altiplanicie No.11, "Torre
Volken" Piso 2
Col. Villas de Irapuato C.P. 36670
Irapuato, Gto, Mexico
Tel : +52 (462) 635-7251

Information in this brochure is subject to change without notice.

Hitachi Industrial Equipment Systems Co., Ltd.

For further information, please contact your nearest sales representative.



Registration number: JACO-EC99J2009
Registration date: July 22, 1996

Hitachi Industrial Equipment Systems Co., Ltd. (Taga Administrative division) obtained ISO 14001 certification, an international standard for environmental management systems.

Registration number: JQA-QMA 12087
Registration date: April 1, 2005

Hitachi Industrial Equipment Systems Co., Ltd. (Taga Administrative division) obtained international standard ISO 9001 certification for the quality assurance of the hoist motor block contained in this brochure.